

DIODE MODULE (F.R.D.)

FRD/FDS100BA60



UL;E76102 (M)

FRD (FDS)100BA is a high speed (fast recovery) dual diode module designed for high power switching application. FRD (FDS) 100BA is suitable for high frequency application requiring low loss and high speed control.

- High Speed $t_{rr} \leq 100\text{ns}$
- $I_{F(AV)}$ 100A (each device)
- Isolated mounting construction.
- High Surge Capability

(Applications)

Switching Power Supply, Inverter Welding Power Supply
Power Supply for Telecommunication

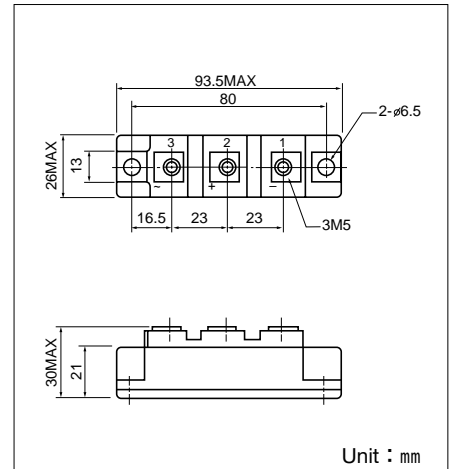
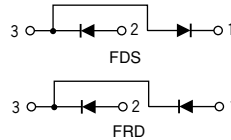

Maximum Ratings

($T_j = 25^\circ\text{C}$ unless otherwise specified)

Symbol	Item	Ratings	Unit
V_{RRM}	Repetitive Peak Reverse Voltage	600	V
$V_{R(DC)}$	D.C. Reverse Voltage	480	V

Symbol	Item	Conditions	Ratings	Unit	
I_F	Forward Current	D.C. $T_c : 94^\circ\text{C}$	100	A	
I_{FSM}	Surge Forward Current	$\frac{1}{2}$ cycle, 60Hz, peak value, non-repetitive	2000	A	
I_t^t	I_t^t	Value for One cycle of surge current	16700	A^2S	
T_j	Operating Junction Temperature		-40 to +150	$^\circ\text{C}$	
T_{stg}	Storage Temperature		-40 to +125	$^\circ\text{C}$	
V_{iso}	Isolation Breakdown Voltage (R.M.S.)	A.C. 1 minute	2500	V	
	Mounting Torque	Mounting(M6)	Recommended Value 2.5-3.9 (25-40)	4.7 (48)	Nm ($\text{kgf}\cdot\text{cm}$)
		Terminal (M5)	Recommended Value 1.5-2.5 (15-25)	2.7 (28)	
	Mass			170	g

Electrical Characteristics

Symbol	Item	Conditions	Ratings		Unit
			Typ.	Max.	
I_{RRM}	Repetitive Peak Reverse Current, max.	$V_R = V_{RRM}, T_j = 125^\circ\text{C}$		100	mA
V_{FM}	Forward Voltage Drop, max.	Forward current 100A, Inst. measurement	1.15	1.3	V
$R_{th(j-c)}$	Thermal Impedance, max.	Junction to case		0.4	$^\circ\text{C}/\text{W}$
t_{rr}	Reverse Recovery Time, max.	$I_F = 100\text{A}, di/dt = -100\text{A}/\mu\text{s}$	85	100	ns

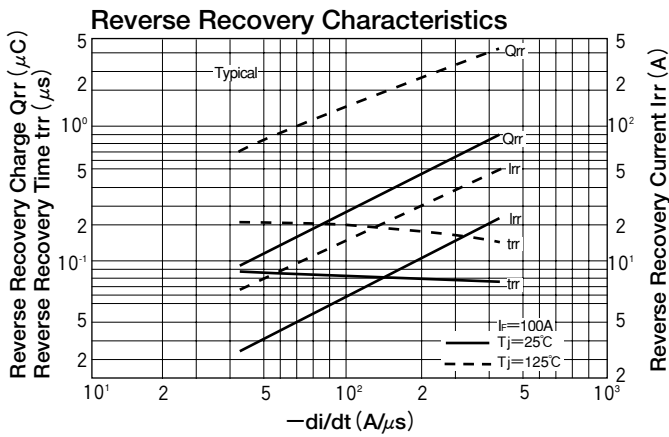
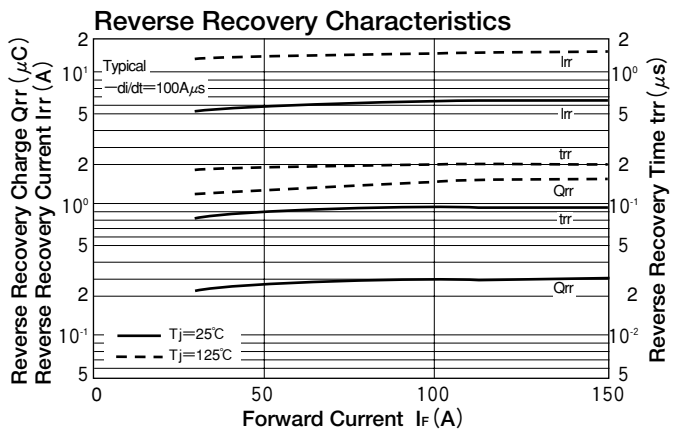
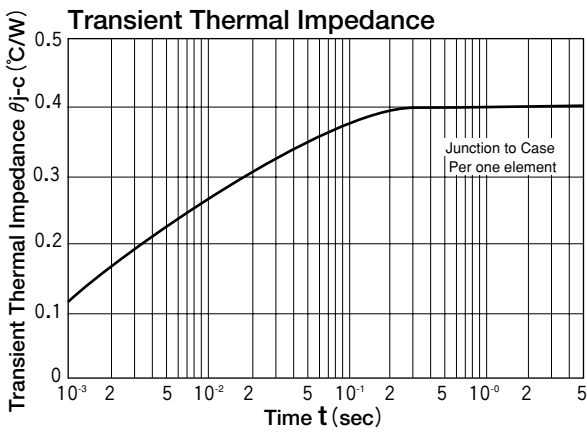
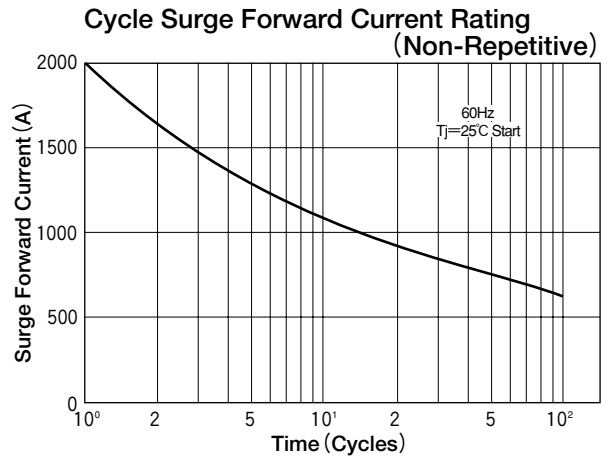
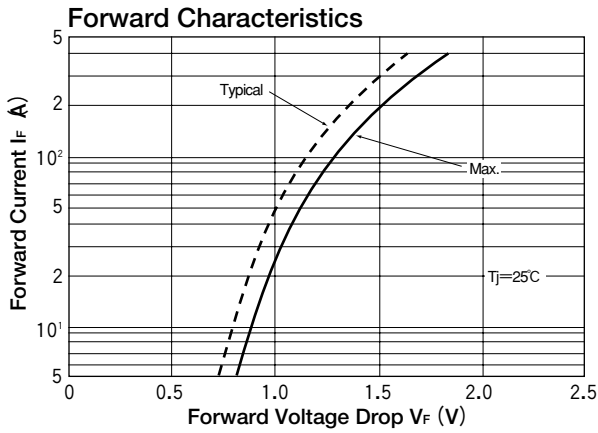

DIODE MODULE (F.R.D.)

FRD100CA100/120



UL;E76102 (M)

FRD100CA is a high speed (fast recovery) dual diode module designed for high power switching application. **FRD100CA** is suitable for high frequency application requiring low loss and high speed control.

- High Speed $t_{rr} \leq 300\text{ns}$
- $I_{F(AV)}$ 100A (each device)
- Isolated mounting construction.
- High Surge Capability

(Applications)

Switching Power Supply. Inverter Welding Power Supply
Power Supply for Telecommunication

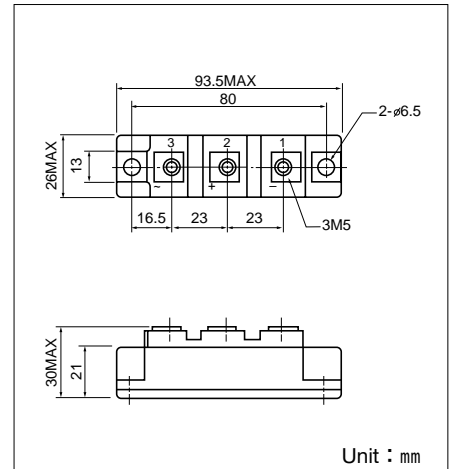

Unit : mm

Maximum Ratings

($T_j = 25^\circ\text{C}$ unless otherwise specified)

Symbol	Item	Ratings		Unit
		FRD100CA100	FRD100CA120	
V_{RRM}	Repetitive Peak Reverse Voltage	1000	1200	V
$V_{R(DC)}$	D.C. Reverse Voltage	800	960	V

Symbol	Item	Conditions	Ratings	Unit	
I_F	Forward Current	D.C. $T_c = 78^\circ\text{C}$	100	A	
I_{FSM}	Surge Forward Current	$\frac{1}{2}$ cycle, 60Hz, peak value, non-repetitive	2000	A	
I^2t	I^2t	Value for one cycle of surge current	16600	A^2S	
T_j	Operating Junction Temperature		-40 to +150	$^\circ\text{C}$	
T_{stg}	Storage Temperature		-40 to +125	$^\circ\text{C}$	
V_{iso}	Isolation Breakdown Voltage (R.M.S.)	A.C. 1 minute	2500	V	
	Mounting Torque	Mounting (M6)	Recommended Value 2.5-3.9 (25-40)	4.7 (48)	N·m (kgf·cm)
		Terminal (M5)	Recommended Value 1.5-2.5 (15-25)	2.7 (28)	
	Mass	Typical Value	170	g	

Electrical Characteristics

Symbol	Item	Conditions	Ratings			Unit
			Min.	Typ.	Max.	
I_{RRM}	Repetitive Peak Reverse Current	$V_R = V_{RRM}$, $T_j = 150^\circ\text{C}$			5.0	mA
V_{FM}	Forward Voltage Drop	$I_F = 100\text{A}$, Inst. measurement			1.8	V
t_{rr}	Reverse Recovery Time	$I_F = 100\text{A}$, $-di/dt = 100\text{A}/\mu\text{s}$			300	ns
$R_{th(j-c)}$	Thermal Impedance	Junction to case			0.4	$^\circ\text{C}/\text{W}$

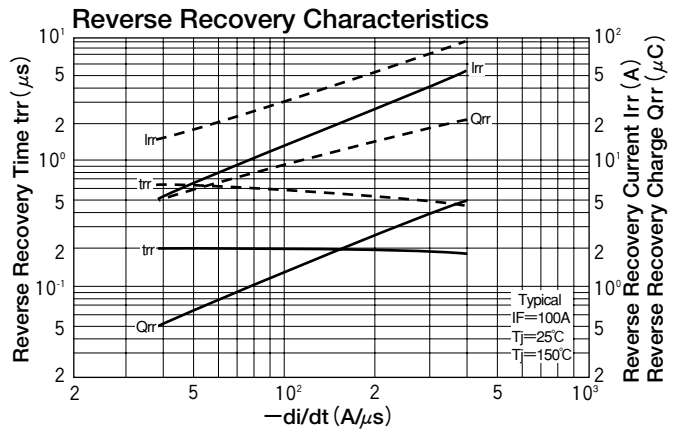
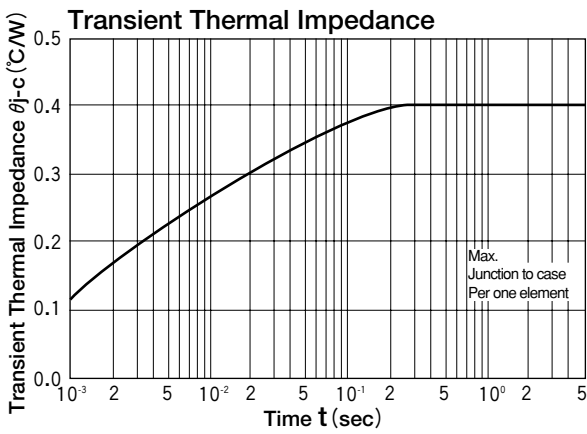
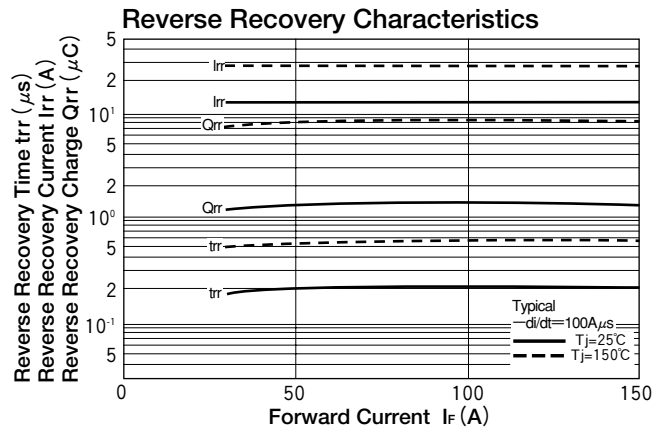
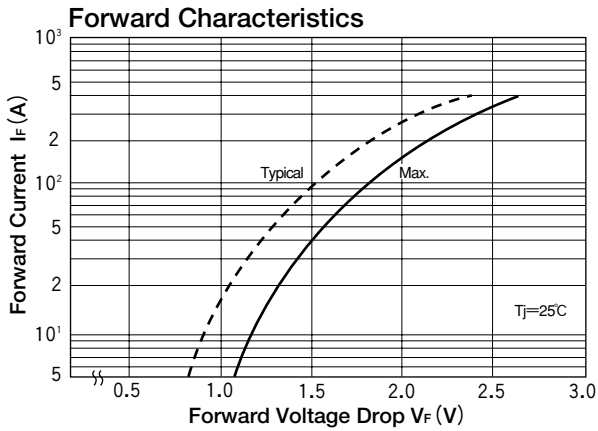

DIODE MODULE (F.R.D.)

FDS100CA100/120



UL;E76102 (M)

FDS100CA is a high speed (fast recovery) diode module designed for high power switching application. FDS100CA is suitable for high frequency application requiring low loss and high speed control.

- High Speed $t_{rr} \leq 300\text{ns}$
- $I_{F(AV)}$ 100A (each device)
- Isolated mounting construction.
- High Surge Capability

(Applications)

Switching Power Supply. Inverter Welding Power Supply
Power Supply for Telecommunication

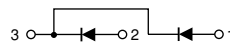
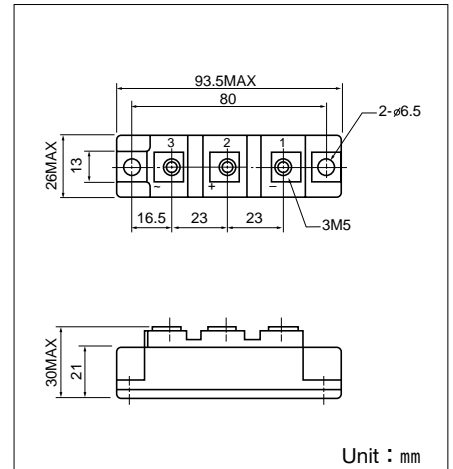

Maximum Ratings

($T_j=25^\circ\text{C}$ unless otherwise specified)

Symbol	Item	Ratings		Unit
		FDS100CA100	FDS100CA120	
V_{RRM}	Repetitive Peak Reverse Voltage	1000	1200	V
$V_{R(DC)}$	D.C. Reverse Voltage	800	960	V

Symbol	Item	Conditions	Ratings	Unit	
I_F	Forward Current	D.C. $T_c=78^\circ\text{C}$	100	A	
I_{FSM}	Surge Forward Current	$\frac{1}{2}$ cycle, 60Hz, peak value, non-repetitive	2000	A	
I^2t	I^2t	Value for one cycle of surge current	16600	A^2S	
T_j	Operating Junction Temperature		-40 to +150	$^\circ\text{C}$	
T_{stg}	Storage Temperature		-40 to +125	$^\circ\text{C}$	
V_{iso}	Isolation Breakdown Voltage (R.M.S.)	A.C. 1 minute	2500	V	
	Mounting Torque	Mounting(M6)	Recommended Value 2.5-3.9 (25-40)	4.7 (48)	N·m (kgf·cm)
		Terminal (M5)	Recommended Value 1.5-2.5 (15-25)	2.7 (28)	
	Mass	Typical Value	170	g	

Electrical Characteristics

Symbol	Item	Conditions	Ratings			Unit
			Man.	Typ.	Max.	
I_{RRM}	Repetitive Peak Reverse Current	$V_R=V_{RRM}$, $T_j=150^\circ\text{C}$			5.0	mA
V_{FM}	Forward Voltage Drop	$I_F=100\text{A}$, Inst. measurement			1.8	V
t_{rr}	Reverse Recovery Time	$I_F=100\text{A}$, $-di/dt=100\text{A}/\mu\text{s}$			300	ns
$R_{th(j-c)}$	Thermal Impedance	Junction to case			0.4	$^\circ\text{C}/\text{W}$

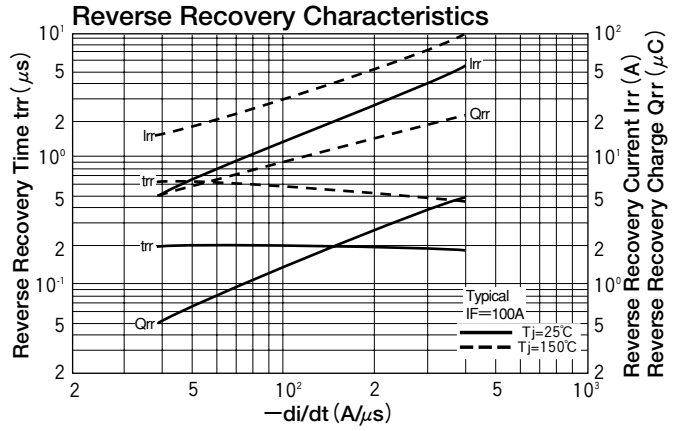
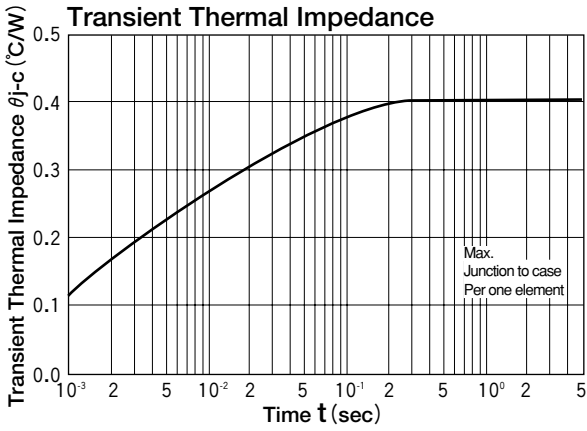
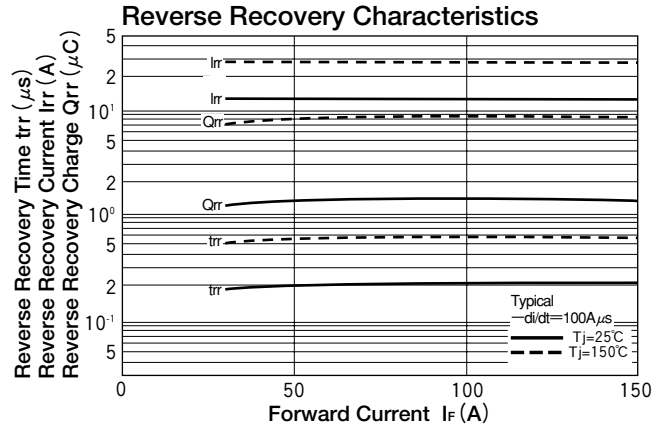
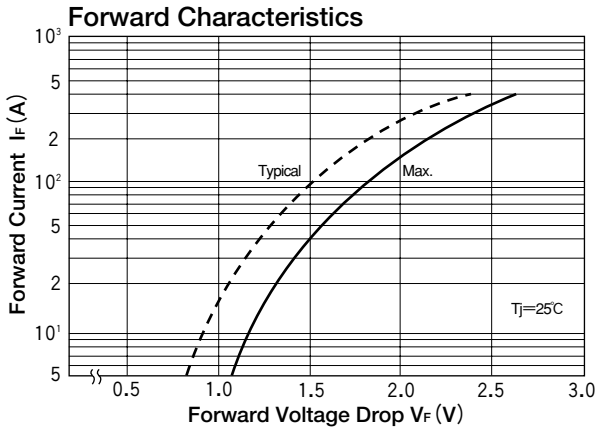

DIODE MODULE (NON-ISOLATED TYPE)

DKR200AB60

TOP



DKR200AB60 is a high speed (fast recovery) dual diode module designed for high power switching application. DKR200AB60 is suitable for high frequency application requiring low loss and high speed control.

- High Speed Diode $t_{rr} \leq 200\text{ns}$
 - $I_{F(AV)} = 100\text{A}$ (each device)
 - High Surge Capability
- (Applications)

Switching Power Supply, Inverter Welding Power Supply
Power Supply for Telecommunication

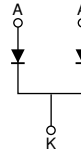
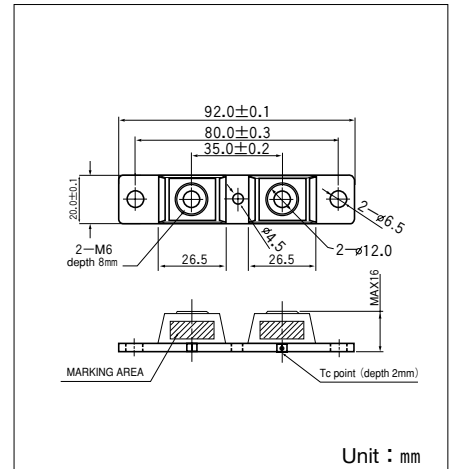

Unit : mm

Maximum Ratings

($T_j = 25^\circ\text{C}$ unless otherwise specified)

Symbol	Item	Ratings		Unit
		DKR200AB60		
V_{RRM}	Repetitive peak reverse Voltage	600		V
$V_{R(DC)}$	D.C. Reverse Voltage	480		V

Symbol	Item		Condition	Ratings	Unit
I_F	Forward Current	Per module	D.C. $T_c = 133^\circ\text{C}$	200	A
		Per leg		100	
I_{FSM}	Surge Forward Current		$\frac{1}{2}$ cycle, 60Hz, Peak value. non-repetitive	3600	A
			$\frac{1}{2}$ cycle, 50Hz, Peak value. non-repetitive	3200	
I^2t	I^2t (for fusing)		Value for one cycle surge current	54000	A^2S
T_j	Operating Junction Temperature			-40 to $+150$	$^\circ\text{C}$
T_{stg}	Storage Temperature			-40 to $+125$	$^\circ\text{C}$
	Mounting Torque	Mounting (M6)	Recommended Value 25-40	48	$(\text{kgf} \cdot \text{cm})$
			Recommended Value 2.5-3.9	4.7	$\text{N} \cdot \text{m}$
		Mounting (M4)	Recommended Value 10-14	15	$(\text{kgf} \cdot \text{cm})$
			Recommended Value 1.0-1.4	1.5	$\text{N} \cdot \text{m}$
		Terminal (M6)	Recommended Value 25-40	48	$(\text{kgf} \cdot \text{cm})$
			Recommended Value 2.5-3.9	4.7	$\text{N} \cdot \text{m}$
	Mass	Typical Value		80	g

Electrical Characteristics

Symbol	Item	Condition	Ratings			Unit
			Min.	Typ.	Max.	
I_{RRM}	Repetitive Peak Reverse Current	$T_j = 125^\circ\text{C}$, $V_D = V_{RRM}$			200	mA
V_{FM}	Forward Voltage Drop	$I_F = 200\text{A}$, Inst.measurement			1.4	V
t_{rr}	Reverse Recovery Time	$I_F = 200\text{A}$, $-di/dt = 200\text{A}/\mu\text{s}$		100	200	ns
$R_{th(j-c)}$	Thermal Impedance	Junction to case, $\frac{1}{2}$ module			0.063	$^\circ\text{C}/\text{W}$

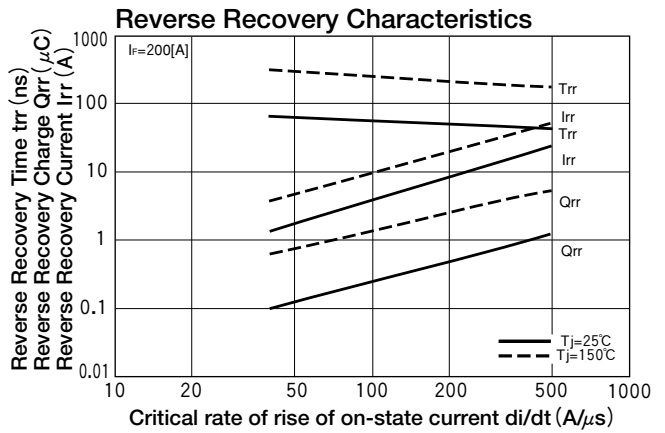
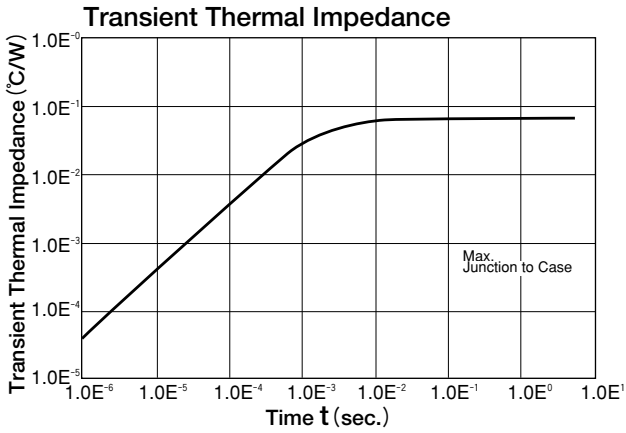
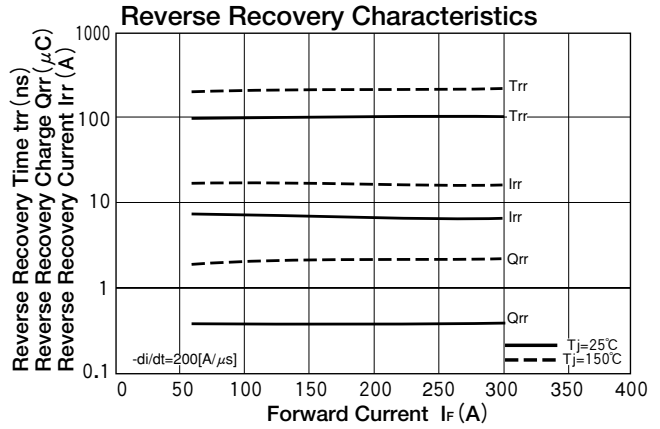
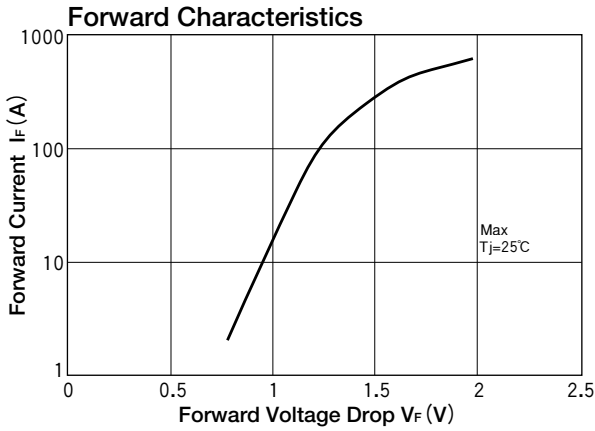

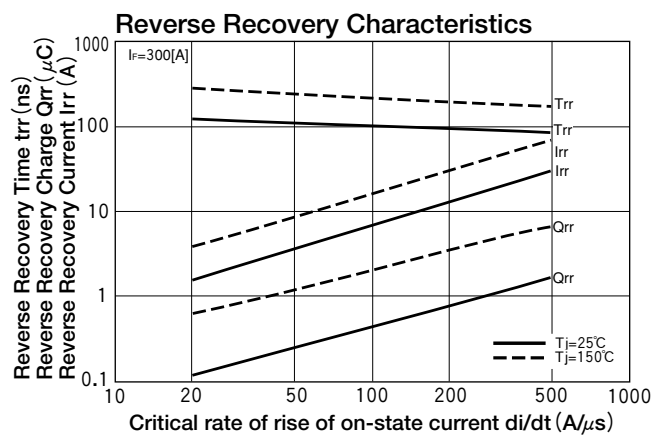
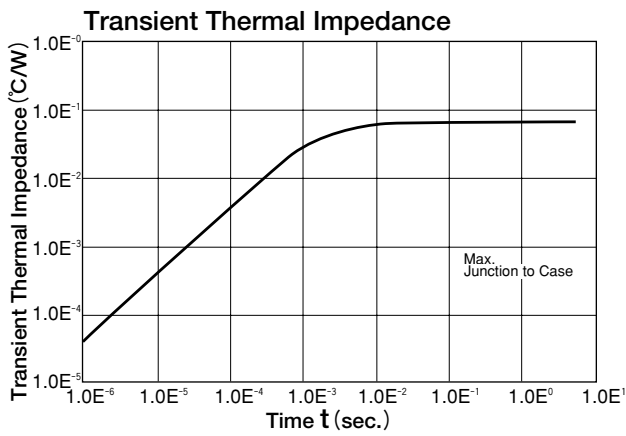
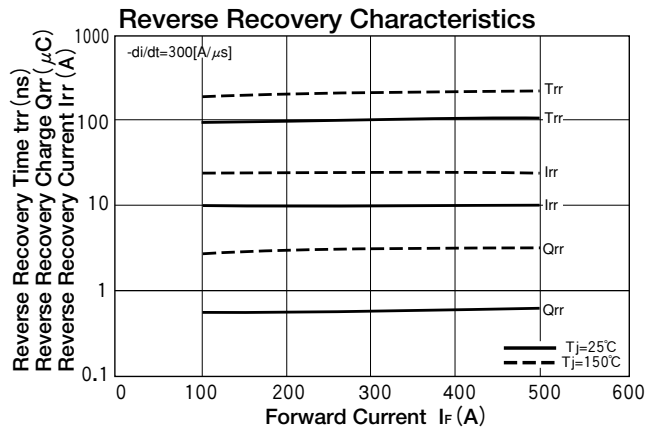
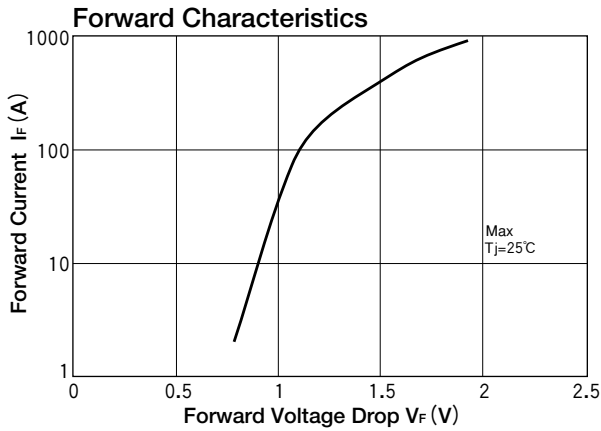

DIODE MODULE (NON-ISOLATED TYPE)

DKR400AB60

TOP



DKR400AB60 is a high speed (fast recovery) dual diode module designed for high power switching application. DKR400AB60 is suitable for high frequency application requiring low loss and high speed control.

● High Speed Diode $t_{rr} \leq 200\text{ns}$

● $I_{F(AV)}=200\text{A}$ (each device)

● High Surge Capability
(Applications)

Switching Power Supply, Inverter Welding Power Supply
Power Supply for Telecommunication

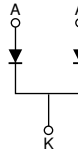
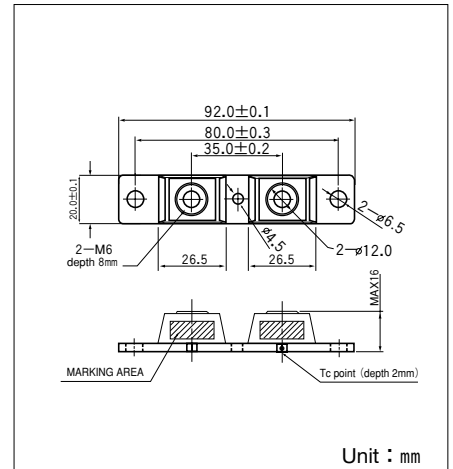

Maximum Ratings

($T_j=25^\circ\text{C}$ unless otherwise specified)

Symbol	Item	Ratings		Unit
		DKR400AB60		
V_{RRM}	Repetitive peak reverse Voltage	600		V
$V_{R(DC)}$	D.C. Reverse Voltage	480		V

Symbol	Item		Condition	Ratings	Unit
I_F	Forward Current	Per module	D.C. $T_c=122^\circ\text{C}$	400	A
		Per leg		200	
I_{FSM}	Surge Forward Current		$\frac{1}{2}$ cycle, 60Hz, Peak value. non-repetitive	6000	A
			$\frac{1}{2}$ cycle, 50Hz, Peak value. non-repetitive	5400	
I^2t	I^2t (for fusing)		Value for one cycle surge current	150000	A^2S
T_j	Operating Junction Temperature			-40 to $+150$	$^\circ\text{C}$
T_{stg}	Storage Temperature			-40 to $+125$	$^\circ\text{C}$
	Mounting Torque	Mounting (M6)	Recommended Value 25-40	48	$(\text{kgf}\cdot\text{cm})$
			Recommended Value 2.5-3.9	4.7	$\text{N}\cdot\text{m}$
		Mounting (M4)	Recommended Value 10-14	15	$(\text{kgf}\cdot\text{cm})$
			Recommended Value 1.0-1.4	1.5	$\text{N}\cdot\text{m}$
		Terminal (M6)	Recommended Value 25-40	48	$(\text{kgf}\cdot\text{cm})$
			Recommended Value 2.5-3.9	4.7	$\text{N}\cdot\text{m}$
	Mass	Typical Value		80	g

Electrical Characteristics

Symbol	Item	Condition	Ratings			Unit
			Min.	Typ.	Max.	
I_{RRM}	Repetitive Peak Reverse Current	$T_j=125^\circ\text{C}$, $V_D=V_{RRM}$			300	mA
V_{FM}	Forward Voltage Drop	$I_F=400\text{A}$, Inst.measurement			1.4	V
t_{rr}	Reverse Recovery Time	$I_F=400\text{A}$, $-di/dt=400\text{A}/\mu\text{s}$		100	200	ns
$R_{th(j-c)}$	Thermal Impedance	Junction to case, $\frac{1}{2}$ module			0.05	$^\circ\text{C}/\text{W}$

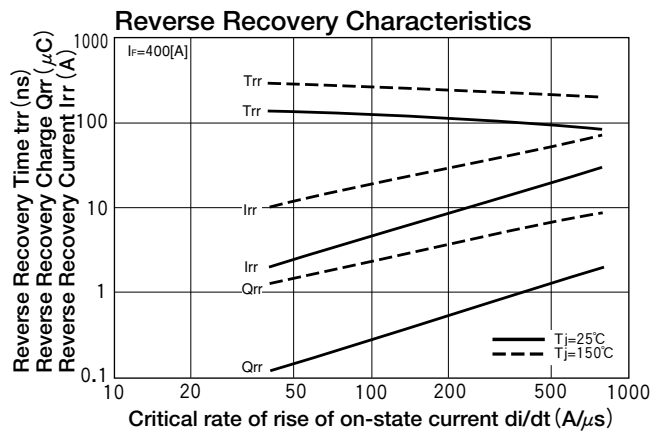
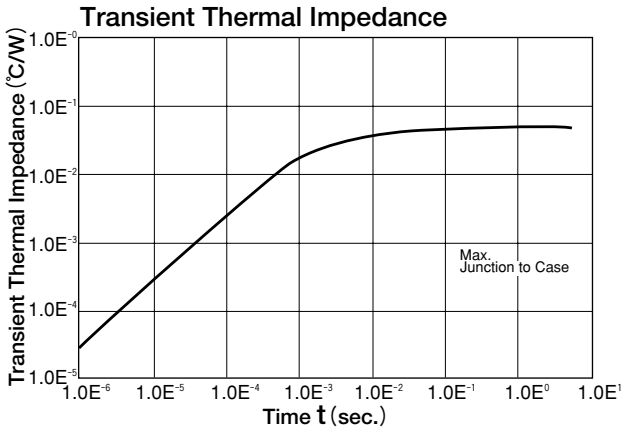
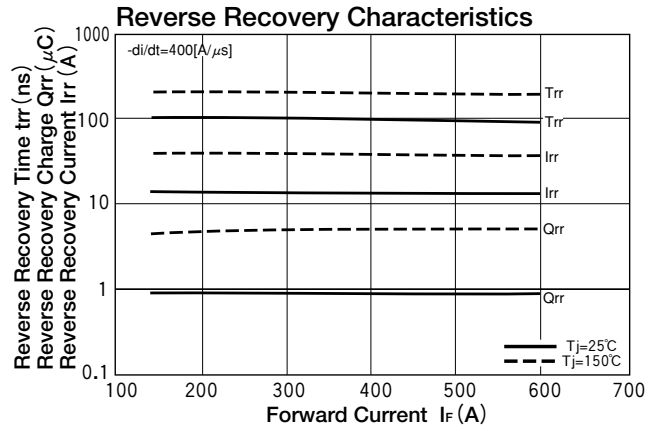
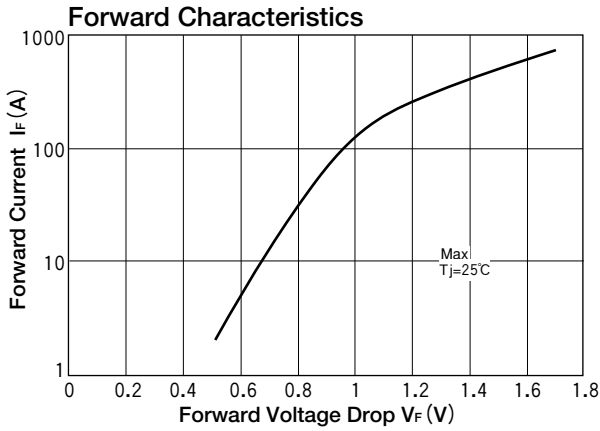

DIODE MODULE (F.R.D.)

FDF25CA100/120

TOP



UL;E76102 (M)

Power Diode Module **FDF25CA** is designed for single phase full wave rectification, which has four fast recovery diodes connected in a single phase bridge configuration. **FDF25CA** is suitable for high frequency application requiring low loss and high speed control.

- High Speed $t_{rr} \leq 200\text{ns}$
- $I_D = 25\text{A}$
- Isolated mounting construction.
- High Surge Capability

(Applications)

Switching Power Supply, Inverter Welding Power Supply
Power Supply for Telecommunication

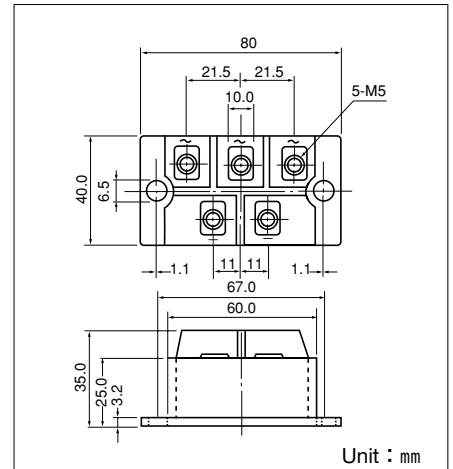
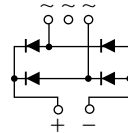

Maximum Ratings

($T_j = 25^\circ\text{C}$ unless otherwise specified)

Symbol	Item	Ratings		Unit
		FDF25CA100	FDF25CA120	
V_{RRM}	Repetitive Peak Reverse Voltage	1000	1200	V
$V_{R(DC)}$	D.C. Reverse Voltage	800	960	V

Symbol	Item	Conditions	Ratings	Unit	
I_D	Output Current (D.C.)	D.C. current. $T_c : 114^\circ\text{C}$	25	A	
I_{FSM}	Surge Forward Current	$\frac{1}{2}$ cycle, 60Hz, peak value, non-repetitive	400	A	
I^2t	I^2t	Value for one cycle of surge current	660	A^2S	
T_j	Operating Junction Temperature		-40 to +150	$^\circ\text{C}$	
T_{stg}	Storage Temperature		-40 to +125	$^\circ\text{C}$	
V_{iso}	Isolation Breakdown Voltage (R.M.S.)	A.C. 1 minute	2500	V	
	Mounting Torque	Muonting(M6)	Recommended Value 2.5-3.9 (25-40)	4.7 (48)	N·m (kgf·cm)
		Terminal (M5)	Recommended Value 1.5-2.5 (15-25)	2.7 (28)	
	Mass	Typical Value	200	g	

Electrical Characteristics

Symbol	Item	Conditions	Ratings			Unit
			Min.	Typ.	Max.	
I_{RRM}	Repetitive Peak Reverse Current	$V_R = V_{RRM}, T_j = 150^\circ\text{C}$			2.0	mA
V_{FM}	Forward Voltage Drop	$I_F = 25\text{A}$, Inst. measurement			1.8	V
t_{rr}	Reverse Recovery Time, (Max.)	$I_F = 25\text{A}$, $-di/dt = 100\text{A}/\mu\text{s}$			200	ns
$R_{th(j-c)}$	Thermal Impedance	Junction to case			0.4	$^\circ\text{C}/\text{W}$

Forward Characteristics

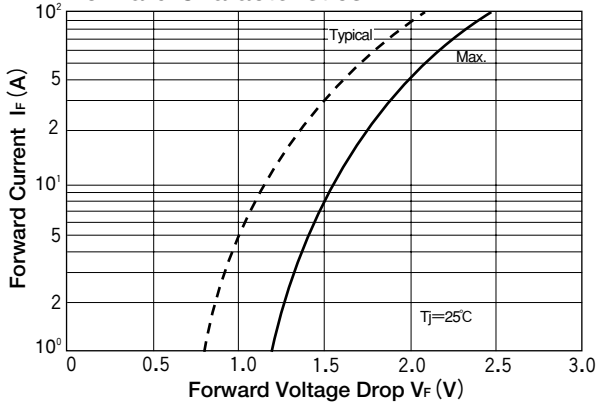

Reverse Recovery Characteristics

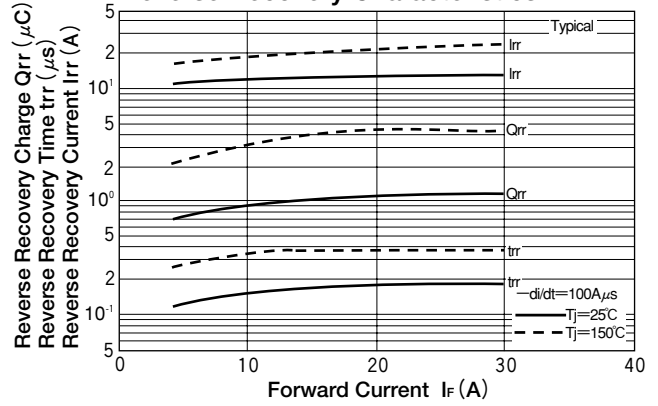

Transient Thermal Impedance

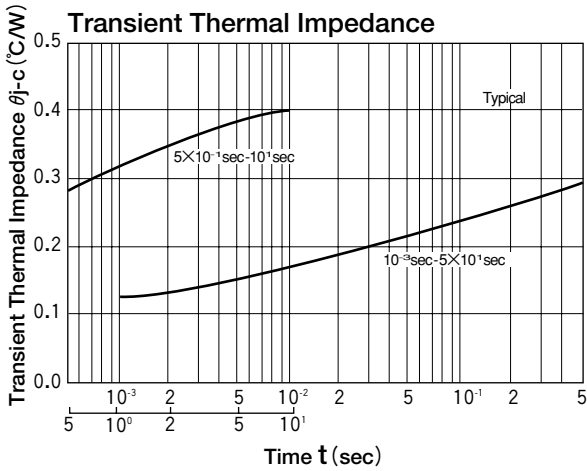

Reverse Recovery Characteristics

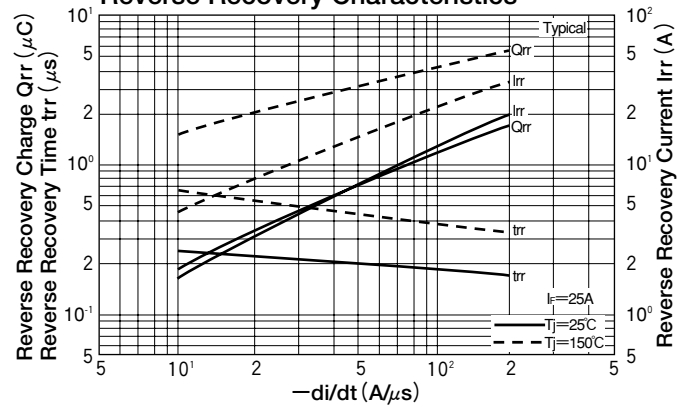

DIODE MODULE (F.R.D.)

FDF60BA50/60

TOP



UL;E76102 (M)

Power Diode Module **FDF60BA** is designed for single phase full wave rectification, which has four fast recovery diodes connected in a single phase bridge configuration. **FDF60BA** is suitable for high frequency application requiring low loss and high speed control.

- High Speed $t_{rr} \leq 100\text{ns}$
- Output Current, DC60A
- Isolated Mounting base.

(Applications)

Switching Power Supply, Inverter Welding Power Supply
Power Supply for Telecommunication

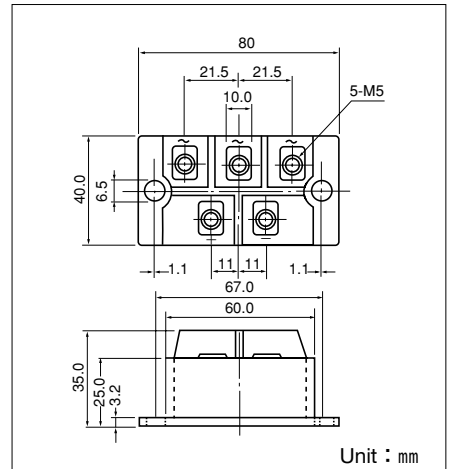
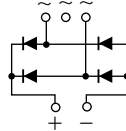

Maximum Ratings

($T_j = 25^\circ\text{C}$ unless otherwise specified)

Symbol	Item	Ratings		Unit
		FDF60BA50	FDF60BA60	
V_{RRM}	Repetitive Peak Reverse Voltage	500	600	V
$V_{R(DC)}$	D.C. Reverse Voltage	400	480	V

Symbol	Item	Conditions	Ratings	Unit	
I_D	Output current	D.C. $T_c : 80^\circ\text{C}$	60	A	
I_{FSM}	Surge Forward Current	$\frac{1}{2}$ cycle, 60Hz, peak value, non-repetitive	600	A	
I^2t	I^2t	Value for one cycle of surge current	1490	A^2S	
T_j	Operating Junction Temperature		-40 to +150	$^\circ\text{C}$	
T_{stg}	Storage Temperature		-40 to +125	$^\circ\text{C}$	
V_{iso}	Isolation Breakdown Voltage (R.M.S.)	A.C. 1 minute	2500	V	
	Mounting Torque	Mounting(M6)	Recommended Value 2.5-3.9 (25-40)	4.7 (48)	N·m (kgf·cm)
		Terminal (M5)	Recommended Value 1.5-2.5 (15-25)	2.7 (28)	
	Mass	Typical Value	200	g	

Electrical Characteristics

Symbol	Item	Conditions	Ratings		Unit
			Typ.	Max.	
I_{RRM}	Repetitive Peak Reverse Current	$V_R = V_{RRM}, T_j = 125^\circ\text{C}$		60	mA
V_{FM}	Forward Voltage Drop	$I_F = 60\text{A}$, Inst. measurement	1.40	1.60	V
t_{rr}	Reverse Recovery Time	$I_F = 60\text{A}$, $-di/dt = 100\text{A}/\mu\text{s}$	85	100	ns
$R_{th(j-c)}$	Thermal Impedance	Junction to case (a module)		0.36	$^\circ\text{C}/\text{W}$

Forward Characteristics

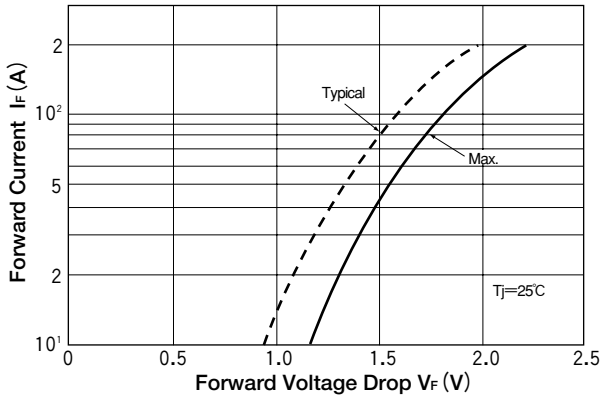

Cycle Surge Forward Current Rating (Non-Repetitive)

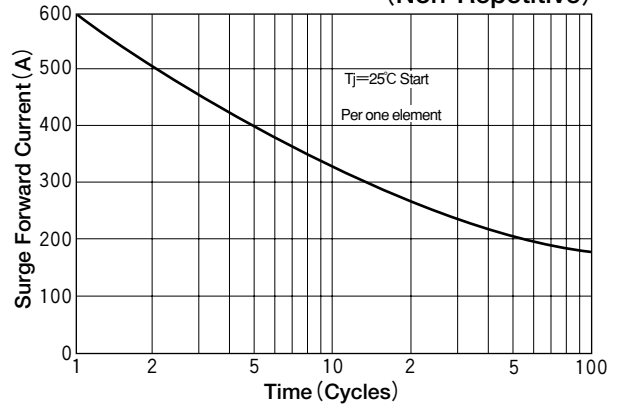

Transient Thermal Impedance

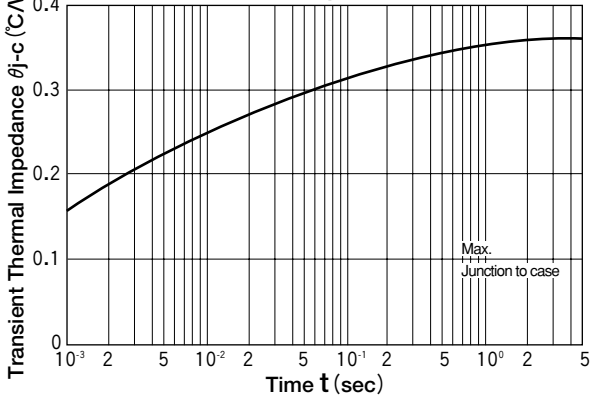

Reverse Recovery Characteristics

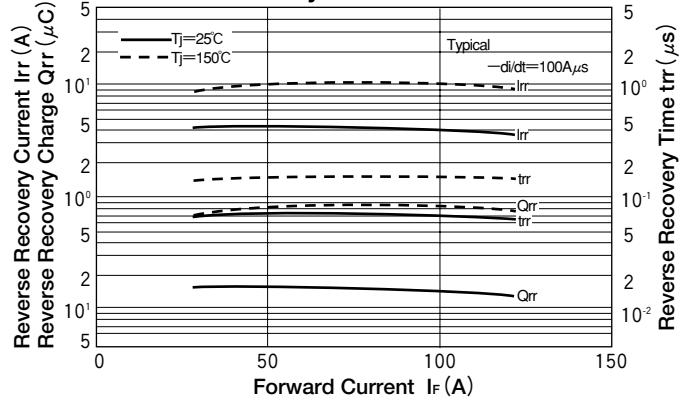

Reverse Characteristics

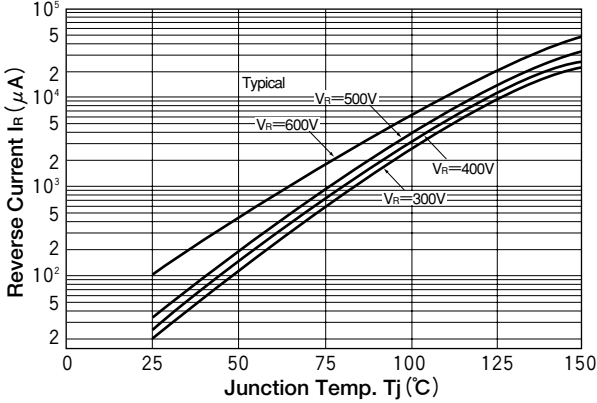

Reverse Recovery Characteristics

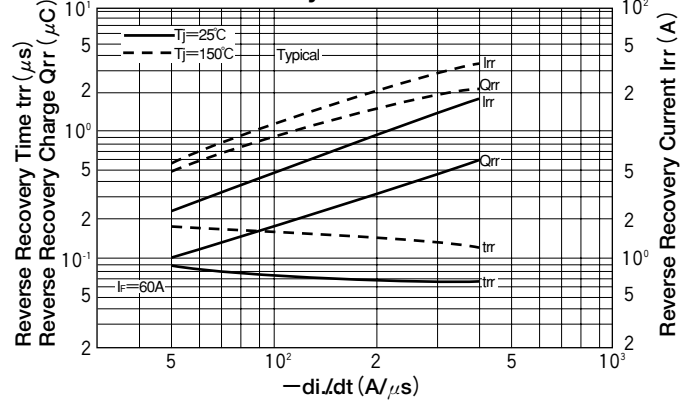

SCHOTTKY DIODE MODULE (NON-ISOLATED TYPE)

BKR400ABZ50

TOP



Power Schottky Diode Module **BKR400AAZ50** is designed for various rectifier circuits.

BKR400AAZ50 is suitable for high power application requiring low loss.

● Low V_{FM} 0.57V ($I_F=400A$)

● $I_{F(AV)}=200A$ (each device)

● $V_{RRM}=50V$

● High Surge Capability

(Applications)

Switching Power Supply, Power Supply for Metal Surface Treatment

Power Supply for Telecommunication

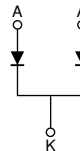
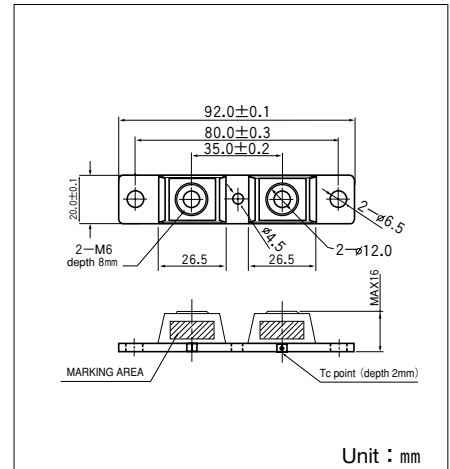

Unit : mm

Maximum Ratings

($T_j=25^\circ C$ unless otherwise specified)

Symbol	Item	Ratings		Unit
		BKR400ABZ50		
V_{RRM}	Repetitive peak reverse Voltage	50		V

Symbol	Item		Condition	Ratings	Unit
$I_{F(AV)}$	Forward Current	Per module	D.C. $T_c=121^\circ C$	400	A
		Per leg		200	
I_{FMS}	Surge Forward Current		$\frac{1}{2}$ cycle, 60Hz, Peak value. non-repetitive	7600	A
			$\frac{1}{2}$ cycle, 50Hz, Peak value. non-repetitive	6920	
I^2t	I^2t (for fusing)			240000	A^2s
E_{AS}	Single Pulse Avalanche Energy (Per Leg)		$I_{AS}=60A, L=160\mu H$	320	mJ
T_j	Operating Junction Temperature			-40 to +150	$^\circ C$
T_{stg}	Storage Temperature			-40 to +125	$^\circ C$
	Mounting Torque	Mounting (M6)	Recommended value 25-40	48	(kgf·cm)
			Recommended value 2.5-3.9	4.7	N·m
		Mounting (M4)	Recommended value 10-14	15	(kgf·cm)
			Recommended value 1.0-1.4	1.5	N·m
		Terminal (M6)	Recommended value 25-40	48	(kgf·cm)
			Recommended value 2.5-3.9	4.7	N·m
	Mass	Typical value		78	g

Electrical Characteristics

Symbol	Item	Condition	Ratings	Unit
I_{RRM}	Repetitive Peak Reverse Current	$T_j=125^\circ C, V_R=50V, \text{Pulse Width}<300\mu s, \text{Duty}<2\%$	2000	mA
V_{FM}	Forward Voltage Drop	$I_F=400A$	0.57	V
		$I_F=800A$	0.73	
		$I_F=400A, T_j=125^\circ C$	0.52	
		$I_F=800A, T_j=125^\circ C$	0.68	
$R_{th(j-c)}$	Thermal Impedance	Junction to case, $\frac{1}{2}$ module	0.1	$^\circ C/W$

