

DIODE MODULE (F.R.D.)

FRG25BA60

TOP



UL;E76102 (M)

FRG25BA60 is a high speed (fast recovery) isolated diode module designed for high power switching application. FRG25BA60 is suitable for high frequency application requiring low loss and high speed control.

- High Speed $t_{rr} \leq 100\text{ns}$
- $I_{F(AV)}$ 25A
- Isolated Mounting base.
- High Surge Capability

(Applications)

Inverter Welding Power Supply
 Power Supply for Telecommunication
 Various Switching Power Supply.

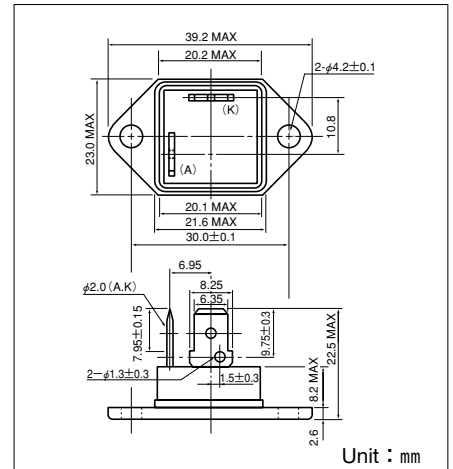
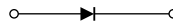

Maximum Ratings

($T_j=25^\circ\text{C}$ unless otherwise specified)

Symbol	Item	Ratings	Unit
		FRG25BA60	
V_{RRM}	Repetitive Peak Reverse Voltage	600	V
$V_{R(DC)}$	D.C. Reverse Voltage	480	V

Symbol	Item	Conditions	Ratings	Unit
$I_{F(AV)}$	Forward Current	D.C. $T_c=94^\circ\text{C}$	25	A
I_{FMS}	Surge Forward Current	$1/2$ cycle, 60Hz, peak value, non-repetitive	450	A
I^2t	I^2t	Value for One cycle of surge current	840	A^2S
T_j	Operating Junction Temperature		-40 to +150	$^\circ\text{C}$
T_{stg}	Storage Temperature		-40 to +125	$^\circ\text{C}$
V_{ISO}	Isolation Breakdown Voltage (R.M.S.)	A.C. 1 minute	2500	V
	Mounting Torque (Mounting M4)	Recommended Value 1.0-1.4 (10-14)	1.5 (15)	$\text{N}\cdot\text{m}$ ($\text{kgf}\cdot\text{cm}$)
	Mass	Typical Value	23	g

Electrical Characteristics

Symbol	Item	Conditions	Ratings			Unit
			Min.	Typ.	Max.	
I_{RRM}	Repetitive Peak Reverse Current	$T_j=150^\circ\text{C}$, at $V_{RRM}=600\text{V}$		25	30	mA
V_{FM}	Forward Voltage Drop	$T_j=25^\circ\text{C}$, $I_F=25\text{A}$, Inst. measurement		1.20	1.30	V
t_{rr}	Reverse Recovery Time	$I_F=25\text{A}$, $-di/dt=100\text{A}/\mu\text{s}$		80	100	ns
$R_{th(j-c)}$	Thermal Impedance	Junction to case			1.6	$^\circ\text{C}/\text{W}$

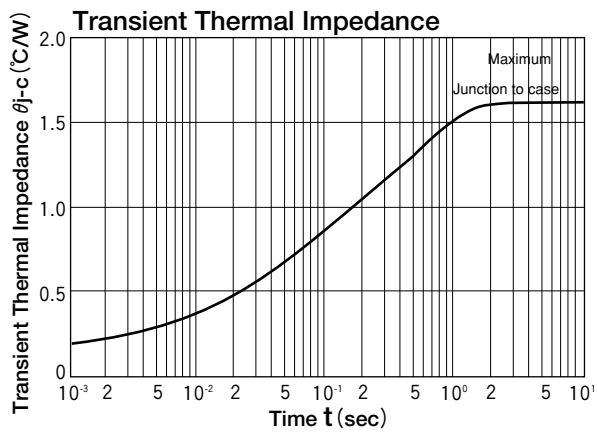
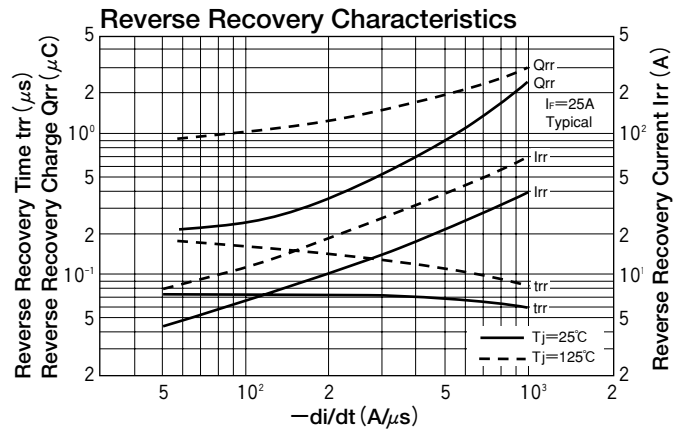
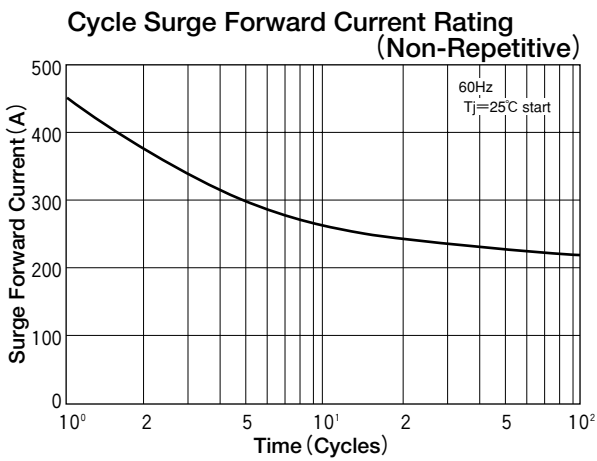
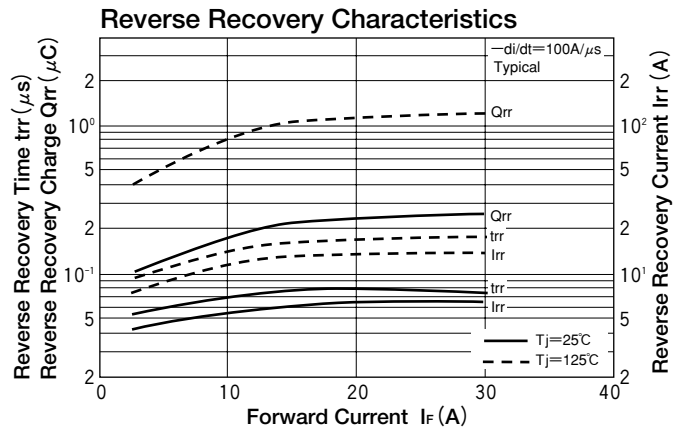
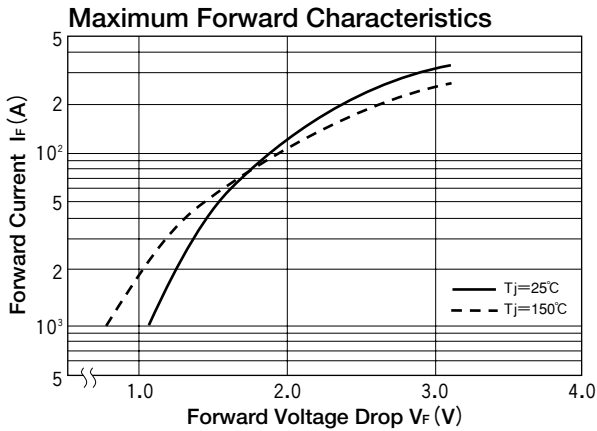

DIODE MODULE (F.R.D.)

FRG25CA120



UL;E76102 (M)

FRG25CA120 is a high speed (fast recovery) isolated diode module designed for high power switching application. FRG25CA120 is suitable for high frequency application requiring low loss and high speed control.

- High Speed $t_{rr} \leq 200\text{ns}$
- $I_{F(AV)}$ 25A
- Isolated Mounting base.
- High Surge Capability

(Applications)

Inverter Welding Power Supply
 Power Supply for Telecommunication
 Various Switching Power Supply.

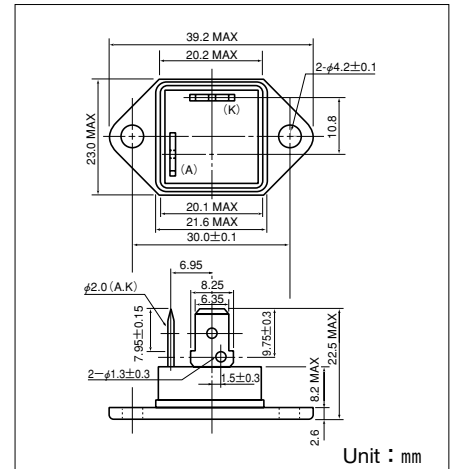
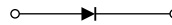

Maximum Ratings

($T_j=25^\circ\text{C}$ unless otherwise specified)

Symbol	Item	Ratings		Unit
		FRG25CA120		
V_{RRM}	Repetitive Peak Reverse Voltage	1200		V
$V_{R(DC)}$	D.C. Reverse Voltage	960		V

Symbol	Item	Conditions	Ratings	Unit
$I_{F(AV)}$	Forward Current	D.C. $T_c:78^\circ\text{C}$	25	A
I_{FMS}	Surge Forward Current	$1/2$ cycle, 60Hz, peak value, non-repetitive	400	A
I^2t	I^2t	Value for one cycle surge current	660	A^2S
T_j	Operating Junction Temperature		-40 to +150	$^\circ\text{C}$
T_{stg}	Storage Temperature		-40 to +125	$^\circ\text{C}$
V_{ISO}	Isolation Breakdown Voltage (R.M.S.)	A.C. 1 minute	2500	V
	Mounting Torque	Mounting M4	Recommended Value 1.0-1.4 (10-14)	1.5 (15) $\text{N}\cdot\text{m}$ ($\text{kgf}\cdot\text{cm}$)
	Mass	Typical Value	23	g

Electrical Characteristics

($T_j=25^\circ\text{C}$ unless otherwise specified)

Symbol	Item	Conditions	Ratings	Unit
I_{RRM}	Repetitive Peak Reverse Current (max.)	$T_j=150^\circ\text{C}$ at $V_{RRM}=1200\text{V}$	1	mA
V_{FM}	Forward Voltage Drop (max.)	$T_j=25^\circ\text{C}$ $I_F=25\text{A}$, Inst. measurement	1.80	V
t_{rr}	Reverse Recovery Time (max.)	$I_F=25\text{A}$, $-di/dt=100\text{A}/\mu\text{s}$	200	ns
$R_{th(j-c)}$	Thermal Impedance (max.)	Junction to case	1.6	$^\circ\text{C}/\text{W}$

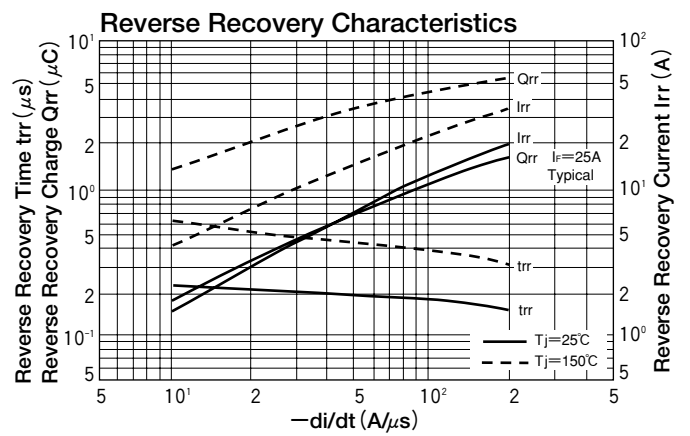
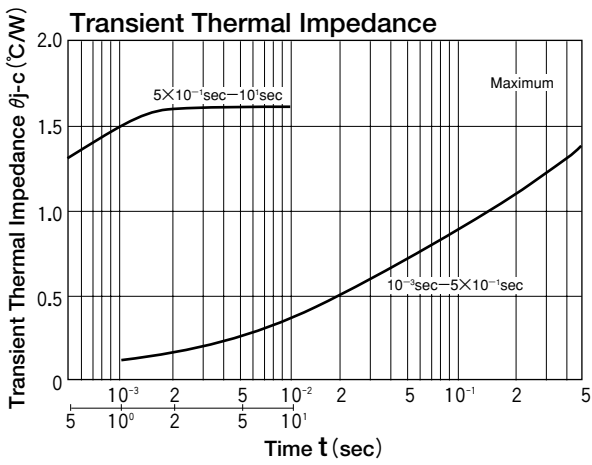
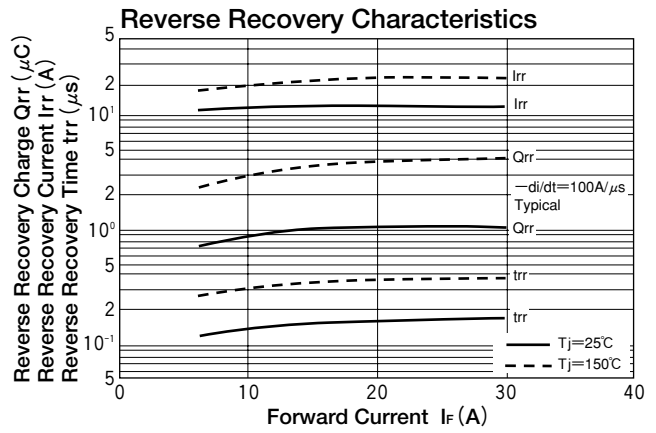
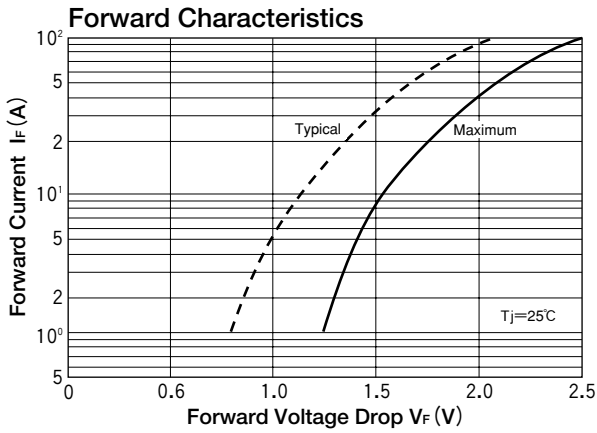

DIODE MODULE (F.R.D.)

FRS150BA50



UL;E76102 (M)

FRS150BA50 is a high speed (fast recovery) isolated diode module designed for high power switching application. FRS150BA50 is suitable for high frequency application requiring low loss and high speed control.

- High Speed $t_{rr} \leq 200\text{ns}$
- $I_F (AV)$ 150A
- Isolated Mounting base.
- High Surge Capability

(Applications)

Inverter Welding Power Supply
 Power Supply for Telecommunication
 Various Switching Power Supply.

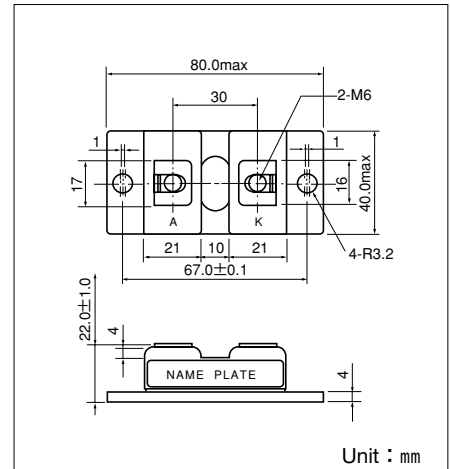
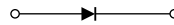

Maximum Ratings

($T_j=25^\circ\text{C}$ unless otherwise specified)

Symbol	Item	Ratings		Unit
		FRS150BA50		
V_{RRM}	Repetitive Peak Reverse Voltage	500		V
$V_{R(DC)}$	D.C. Reverse Voltage	400		V

Symbol	Item	Conditions	Ratings	Unit	
$I_F (AV)$	Forward Current	D.C. $T_c : 85^\circ\text{C}$	150	A	
I_{FMS}	Surge Forward Current	$1/2$ cycle, 60Hz, peak value, non-repetitive	3000	A	
I^2t	I^2t	Value for one cycle of surge current	37500	A^2S	
T_j	Operating Junction Temperature		-40 to +150	$^\circ\text{C}$	
T_{stg}	Storage Temperature		-40 to +125	$^\circ\text{C}$	
V_{ISO}	Isolation Breakdown Voltage (R.M.S.)	A.C. 1 minute	2500	V	
	Mounting Torque	Mounting (M6)	Recommended Value 2.5-3.9 (25-40)	4.7 (48)	N·m (kgf·cm)
		Terminal (M6)	Recommended Value 2.5-3.9 (25-40)	4.7 (48)	
	Mass	Typical Value	170	g	

Electrical Characteristics

Symbol	Item	Conditions	Ratings			Unit
			Min.	Typ.	Max.	
I_{RRM}	Repetitive Peak Reverse Current	$V_{RRM}=500\text{V}$, $T_j=125^\circ\text{C}$			150	mA
V_{FM}	Forward Voltage Drop	$I_F=150\text{A}$, Inst. measurement			1.30	V
t_{rr}	Reverse Recovery Time	$I_F=150\text{A}$, $-di/dt=150\text{A}/\mu\text{s}$			200	ns
$R_{th(j-c)}$	Thermal Impedance	Junction to case			0.33	$^\circ\text{C}/\text{W}$

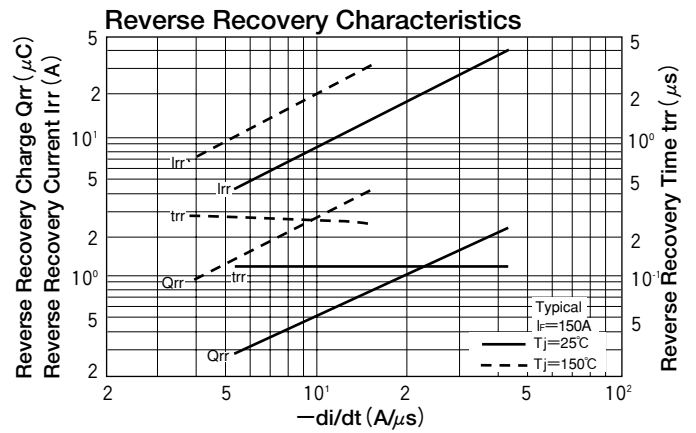
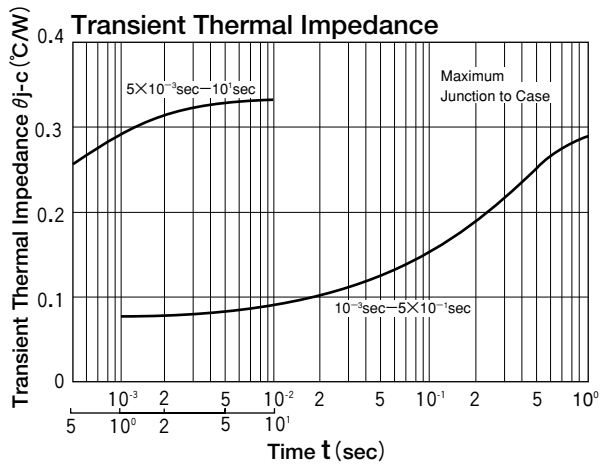
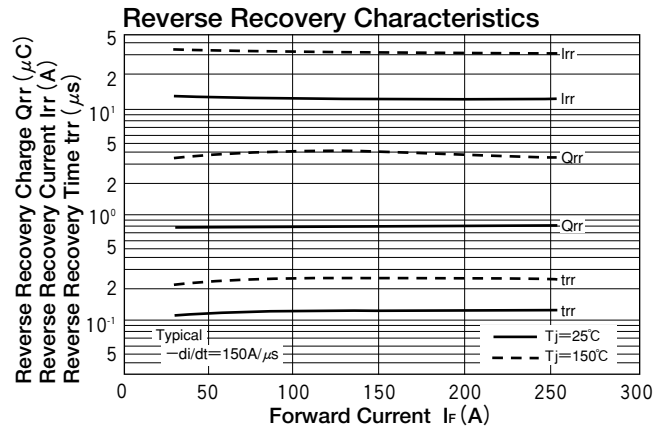
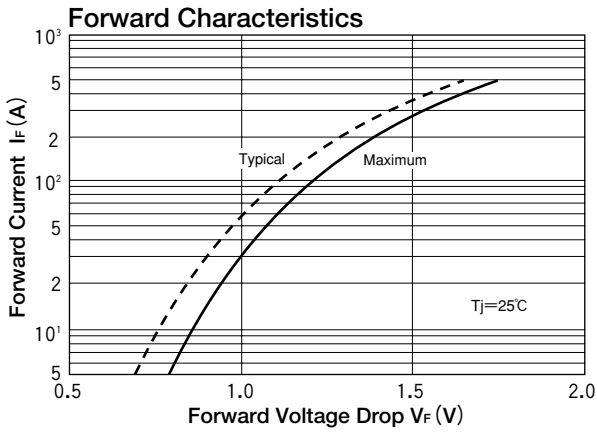

DIODE MODULE (F.R.D.)

MDF(R)150A-L/M

TOP



MDF(R)150A-L/M and MDR150-L/M are high speed (fast recovery) diode with flat mounting base which is designed for switching application of high power.

- $I_{F(AV)} = 150A$ $V_{RRM} = 200/300/400V$
- Easy Construction with Anode (F) Type and Cathode (R) Type
- Reverse Recovery Time (t_{rr}) L Type: 450ns, M Type: 550ns
- Highly Reliability by Grass passivated Chips
- Non isolated type

[MDF:anode to terminal (normal polarity)
MDR:cathode to terminal]

(Applications)

Switching Power Supply.
Inverter Welding Power Supply

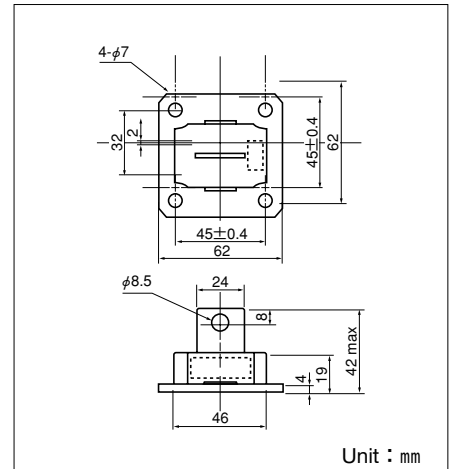
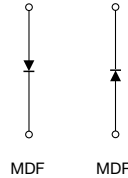

Unit : mm

Maximum Ratings

($T_j = 25^\circ C$ unless otherwise specified)

Symbol	Item	Ratings			Unit
		MDF(R)150A20L/M	MDF(R)150A30L/M	MDF(R)150A40L/M	
V_{RRM}	Repetitive Peak Reverse Voltage	200	300	400	V
V_{RMS}	Non-Repetitive Peak Reverse Voltage	240	360	480	V
$V_{R(DC)}$	D.C. Reverse Voltage	160	240	320	V

Symbol	Item	Conditions	Ratings	Unit	
$I_{F(AV)}$	Average Forward Current	Single phase, half wave, 180° conduction, $T_c: 94^\circ C$	150	A	
$I_{F(RMS)}$	R.M.S. Forward Current	Single phase, half wave, 180° conduction, $T_c: 94^\circ C$	235	A	
I_{FMS}	Surge Forward Current	$1/2$ cycle, 50/60Hz, peak value, non-repetitive	2700/3000	A	
I^2t	I^2t	Value for one cycle of surge current	37500	A^2s	
T_j	Operating Junction Temperature		-30 to $+150$	$^\circ C$	
T_{stg}	Storage Temperature		-30 to $+125$	$^\circ C$	
	Mounting Torque	Mounting (M6)	Recommended Value 2.5-3.9 (25-40)	4.7 (48)	N·m (kgf·cm)
		Terminal (M8)	Recommended Value 8.8-10 (90-105)	11 (115)	
	Mass	Typical Value	170	g	

Electrical Characteristics

Symbol	Item	Conditions	Ratings	Unit	
I_{RRM}	Repetitive Peak Reverse Current (max.)	at V_{RRM} , single phase, half wave, $T_j = 150^\circ C$	50	mA	
V_{FM}	Forward Voltage Drop (max.)	Foward current 470A, $T_j = 25^\circ C$ Inst. measurement	1.30	V	
$R_{th(j-c)}$	Thermal Impedancemax (max.)	Junction to case	0.30	$^\circ C/W$	
t_{rr}	Reverse Recovery Time (max.)	$T_j = 25^\circ C$, $I_F = 2A$, $-di/dt = 20A/\mu s$	L	450	ns
			M	550	

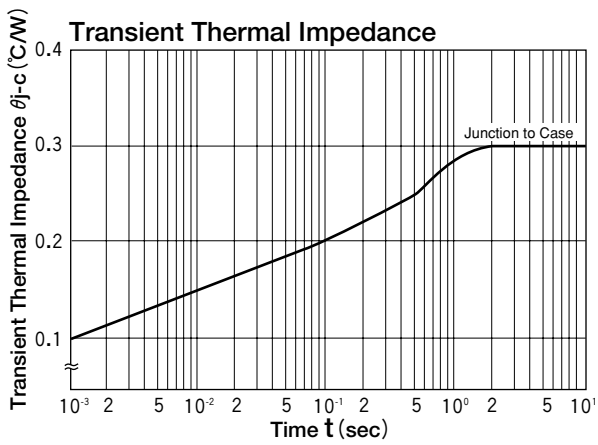
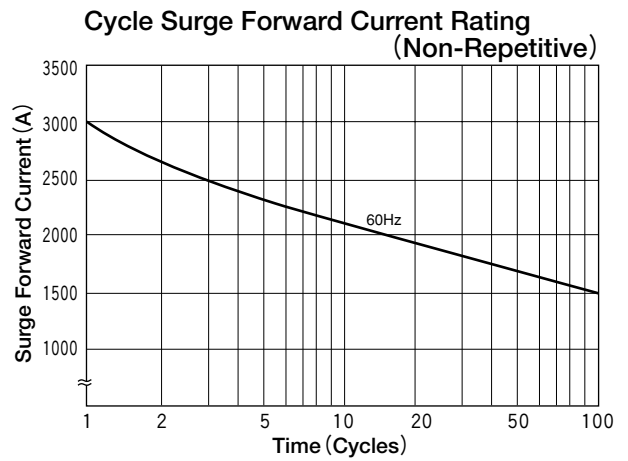
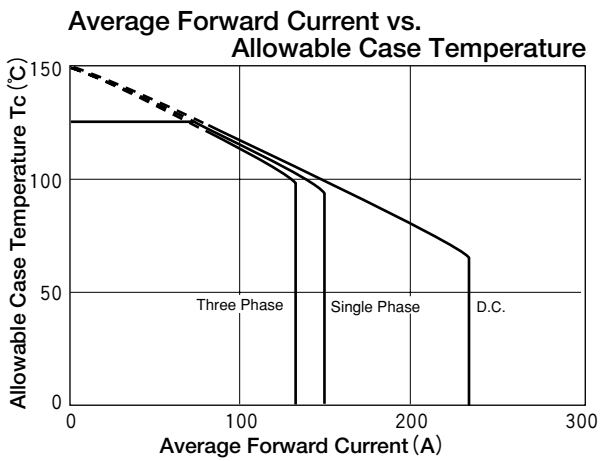
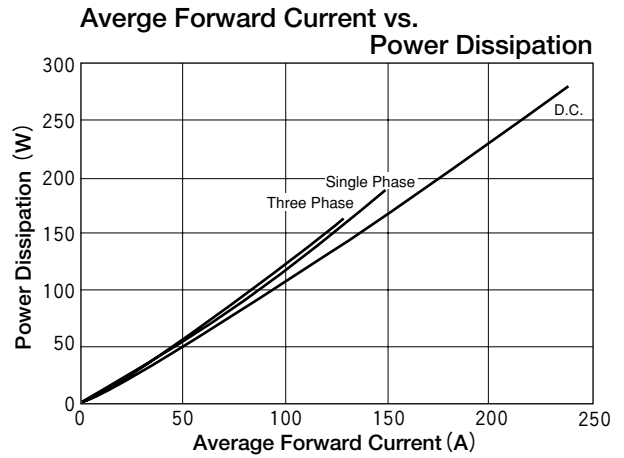
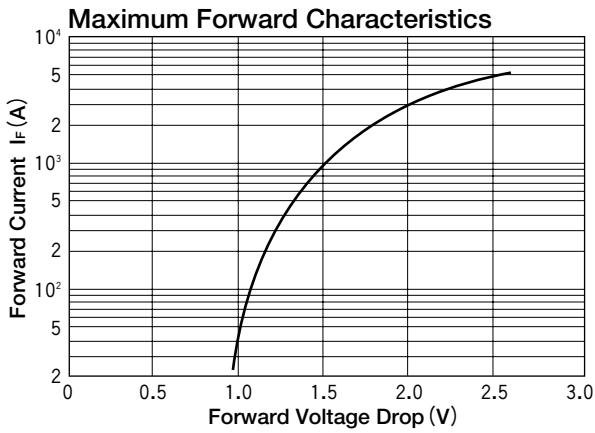

DIODE MODULE (F.R.D.)

FRS200BA50/60



UL;E76102 (M)

FRS200BA is a high speed (fast recovery) isolated diode module designed for high power switching application. FRS200BA is suitable for high frequency application requiring low loss and high speed control.

- High Speed $t_{rr} \leq 100\text{ns}$
- $I_F (AV)$ 200A
- Isolated Mounting base.
- High Surge Capability

(Applications)

Inverter Welding Power Supply
 Power Supply for Telecommunication
 Various Switching Power Supply.

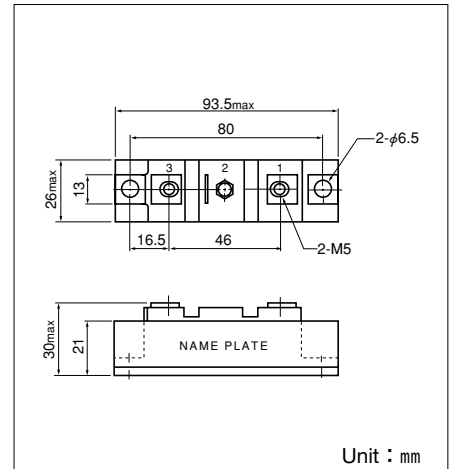
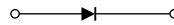

Maximum Ratings

($T_j = 25^\circ\text{C}$ unless otherwise specified)

Symbol	Item	Ratings		Unit
		FRS200BA50	FRS200BA60	
V_{RRM}	Repetitive Peak Reverse Voltage	500	600	V
$V_{R(DC)}$	D.C. Reverse Voltage	400	480	V

Symbol	Item	Conditions	Ratings	Unit	
$I_F (AV)$	Forward Current	D.C. $T_c : 94^\circ\text{C}$	200	A	
I_{FMS}	Surge Forward Current	$\frac{1}{2}$ cycle, 60Hz, peak value, non-repetitive	3300	A	
I^2t	I^2t	Value for One cycle of surge current	45000	A^2S	
T_j	Operating Junction Temperature		-40 to +150	$^\circ\text{C}$	
T_{stg}	Storage Temperature		-40 to +125	$^\circ\text{C}$	
V_{iso}	Isolation Breakdown Voltage (R.M.S.)	A.C. 1 minute	2500	V	
	Mounting Torque	Mounting (M6)	Recommended Value 2.5-3.9 (25-40)	4.7 (48)	$\text{N}\cdot\text{m}$ ($\text{kgf}\cdot\text{cm}$)
		Terminal (M5)	Recommended Value 1.5-2.5 (15-25)	2.7 (28)	
	Mass	Typical Value	170	g	

Electrical Characteristics

($T_j = 25^\circ\text{C}$)

Symbol	Item	Conditions	Ratings			Unit
			Min.	Typ.	Max.	
I_{RRM}	Repetitive Peak Reverse Current (max.)	at V_{RRM} , $T_j = 150^\circ\text{C}$			200	mA
V_{FM}	Forward Voltage Drop (max.)	Forward current 200A, Inst. measurement		1.15	1.3	V
$R_{th(j-c)}$	Thermal Impedance (max.)	Junction to case			0.2	$^\circ\text{C}/\text{W}$
t_{rr}	Reverse Recovery Time (max.)	$I_F = 200\text{A}$, $di/dt = -200\text{A}/\mu\text{s}$		85	100	ns

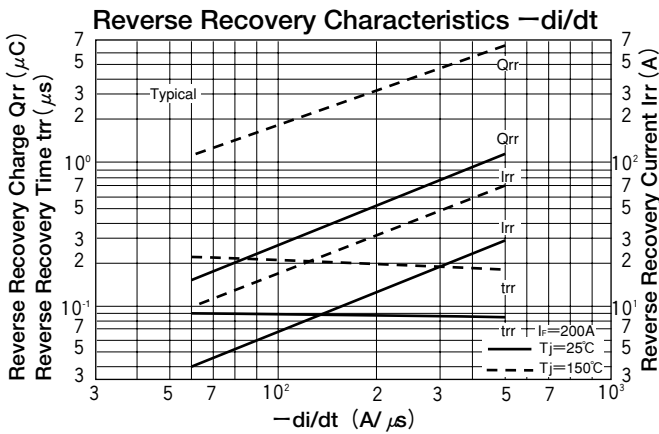
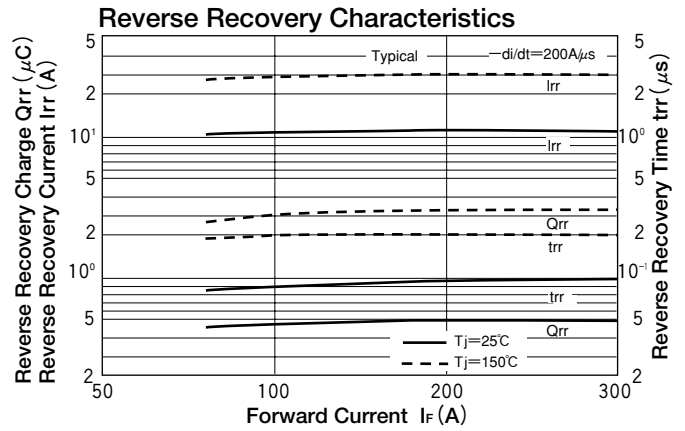
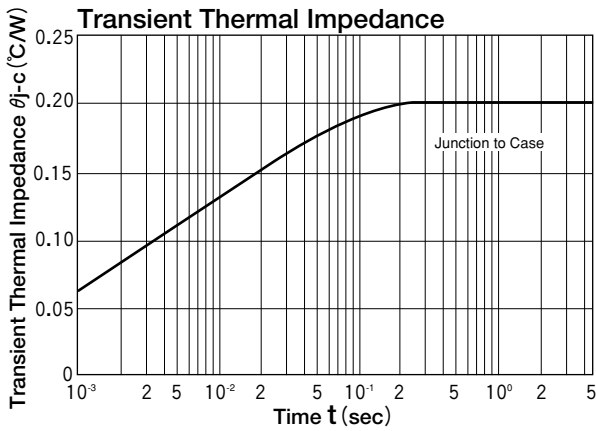
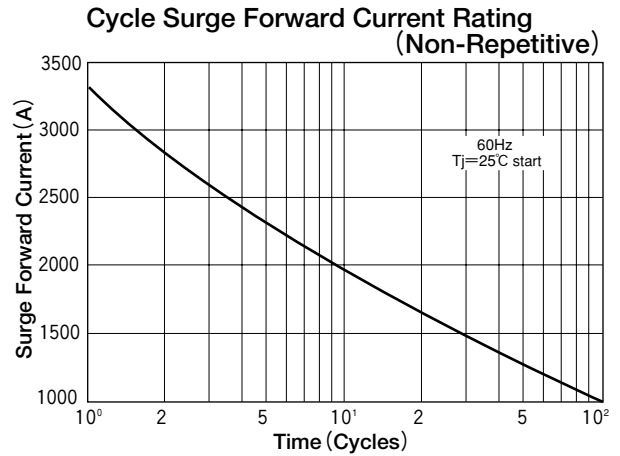
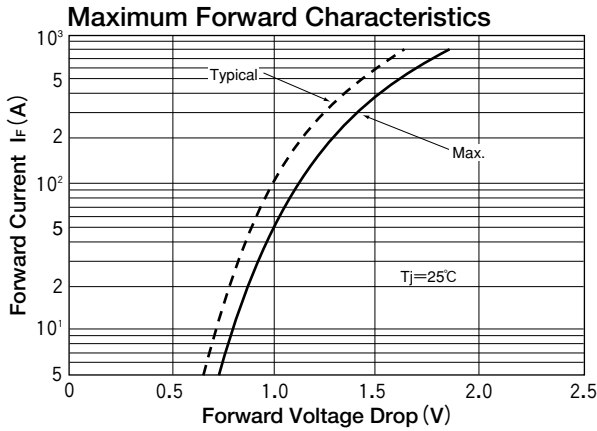

DIODE MODULE (F.R.D.)

FRS200CA100/120



UL;E76102 (M)

FRS200CA is a high speed (fast recovery) isolated diode module designed for high power switching application. FRS200CA is suitable for high frequency application requiring low loss and high speed control.

- High Speed $t_{rr} \leq 350\text{ns}$
- $I_{F(AV)}$ 200A
- Isolated Mounting base.
- High Surge Capability

(Applications)

Inverter Welding Power Supply
 Power Supply for Telecommunication
 Various Switching Power Supply.

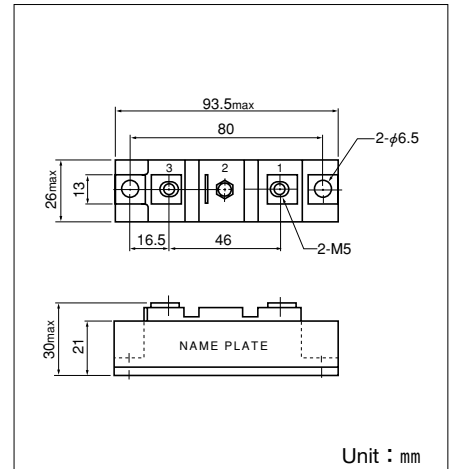
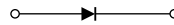

■ **Maximum Ratings**

($T_j=25^\circ\text{C}$ unless otherwise specified)

Symbol	Item	Ratings		Unit
		FRS200CA100	FRS200CA120	
V_{RRM}	Repetitive Peak Reverse Voltage	1000	1200	V
$V_{R(DC)}$	D.C. Reverse Voltage	800	960	V

Symbol	Item	Conditions	Ratings	Unit	
I_F	Forward Current	D.C. $T_c : 78^\circ\text{C}$	200	A	
I_{FSM}	Surge Forward Current	$1/2$ cycle, 60Hz, peak value, non-repetitive	3300	A	
I^2t	I^2t	Value for one cycle of surge current	45000	A^2S	
T_j	Operating Junction Temperature		-40 to +150	$^\circ\text{C}$	
T_{stg}	Storage Temperature		-40 to +125	$^\circ\text{C}$	
V_{ISO}	Isolation Breakdown Voltage (R.M.S.)	A.C. 1 minute	2500	V	
	Mounting Torque	Mounting (M6)	Recommended Value 2.5-3.9 (25-40)	4.7 (48)	N·m (kgf·cm)
		Terminal (M5)	Recommended Value 1.5-2.5 (15-25)	2.7 (28)	
	Mass	Typical Value	170	g	

■ **Electrical Characteristics**

Symbol	Item	Conditions	Ratings			Unit
			Min.	Typ.	Max.	
I_{RRM}	Repetitive Peak Reverse Current	$T_j=150^\circ\text{C}$ at V_{RRM}			10	mA
V_{FM}	Forward Voltage Drop	$T_j=25^\circ\text{C}$ $I_F=200\text{A}$, Inst. measurement			1.8	V
t_{rr}	Reverse Recovery Time	$I_F=200\text{A}$, $-di/dt=200\text{A}/\mu\text{s}$			350	ns
$R_{th(j-c)}$	Thermal Impedance	Junction to case			0.2	$^\circ\text{C}/\text{W}$

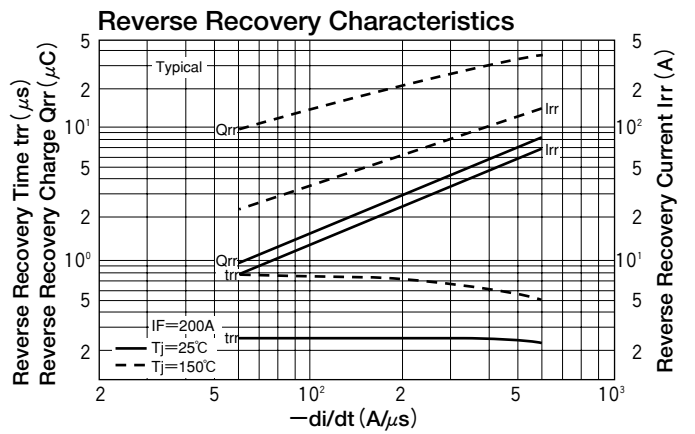
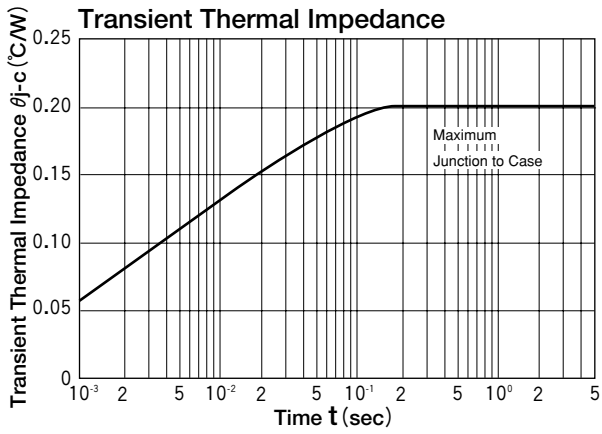
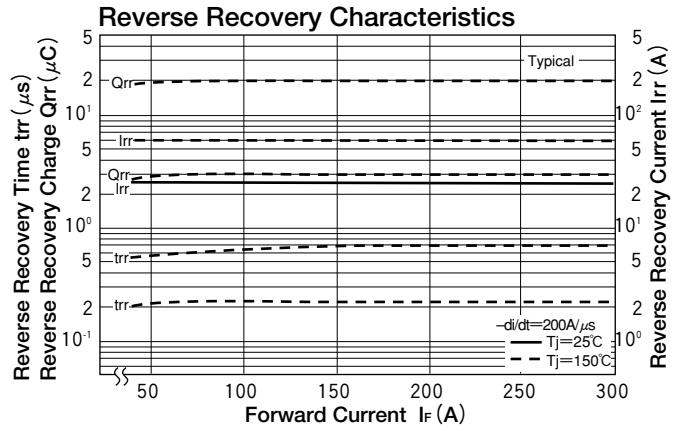
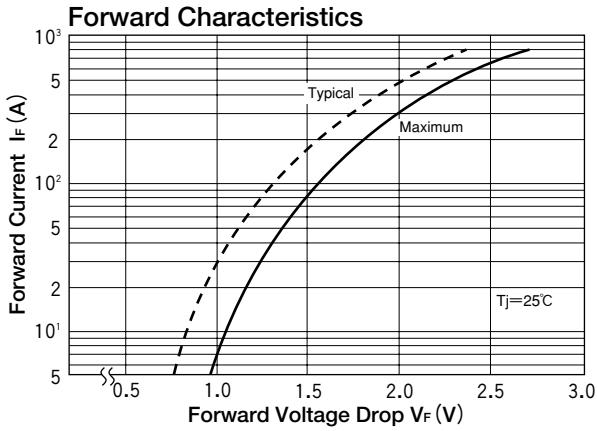

DIODE MODULE (F.R.D.)

MDF(R)250A-L/M

TOP



MDF(R)250A-L/M and MDR150-L/M are high speed (fast recovery) diode with flat mounting base which is designed for switching application of high power.

- $I_{F(AV)}$ 250A $V_{RRM}=200/300/400V$
- Easy Construction with Anode (F) Type and Cathode (R) Type
- [MDF:anode to terminal (normal polarity)
- [MDR:cathode to terminal
- Reverse Recovery Time (t_{rr}) L Type: 450ns, M Type: 550ns
- High Reliability by Glass passivated Chips
- Non isolated type

(Applications)

Switching Power Supply.
Inverter Welding Power Supply

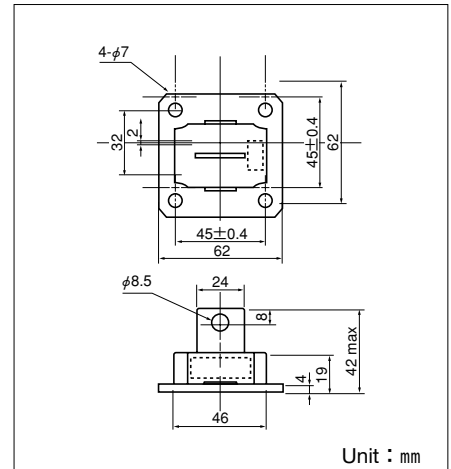
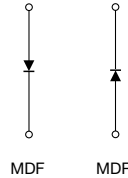

Maximum Ratings

Symbol	Item	Ratings			Unit
		MDF(R)250A20L/M	MDF(R)250A30L/M	MDF(R)250A40L/M	
V_{RRM}	Repetitive Peak Reverse Voltage	200	300	400	V
V_{RSM}	Non-Repetitive Peak Reverse Voltage	240	360	480	V
$V_{R(DC)}$	D.C. Reverse Voltage	160	240	320	V

Symbol	Item	Conditions	Ratings	Unit	
$I_{F(AV)}$	Average Forward Current	Single phase, half wave, 180° conduction, $T_c:L/M 83^\circ/85^\circ C$	250	A	
$I_{F(RSM)}$	R.M.S. Forward Current	Single phase, half wave, 180° conduction, $T_c:L/M 83^\circ/85^\circ C$	390	A	
I_{FMS}	Surge Forward Current	1/2 cycle, 50/60Hz, peak value, non-repetitive	4000/4500	A	
I^2t	I^2t	Value for one cycle of surge current	84000	A ² S	
T_j	Operating Junction Temperature		-30 to +150	°C	
T_{stg}	Storage Temperature		-30 to +125	°C	
	Mounting Torque	Mounting (M6)	Recommended Value 2.5-3.9 (25-40)	4.7 (48)	N·m (kgf·cm)
		Terminal (M8)	Recommended Value 8.8-10 (90-105)	11 (115)	
	Mass	Typical Value	170	g	

Electrical Characteristics

Symbol	Item	Conditions	Ratings	Unit	
I_{RRM}	Repetitive Peak Reverse Current (max.)	at V_{RRM} , single phase, half wave, $T_j=150^\circ C$	60	mA	
V_{FM}	Forward Voltage Drop (max.)	Foward current 800A, $T_j=25^\circ C$ Inst. measurement	L	1.4	V
			M	1.3	
$R_{th(j-c)}$	Thermal Impedance (max.)	Junction to case	0.2	°C/W	
t_{rr}	Reverse Recovery Time (max.)	$T_j=25^\circ C$, $I_F=2A$, $-di/dt=20A/\mu s$	L	450	ns
			M	550	

M Type

Maximum Forward Characteristics

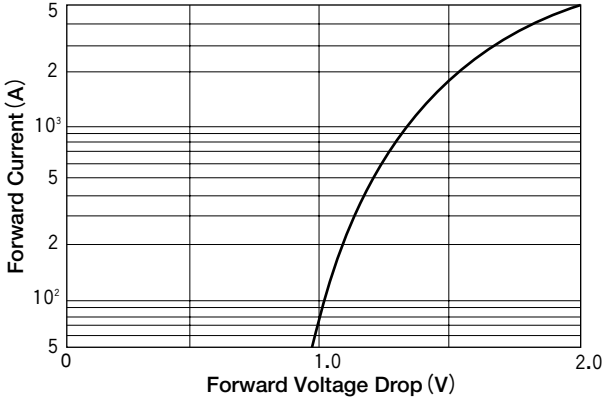

Average Forward Current vs. Power Dissipation

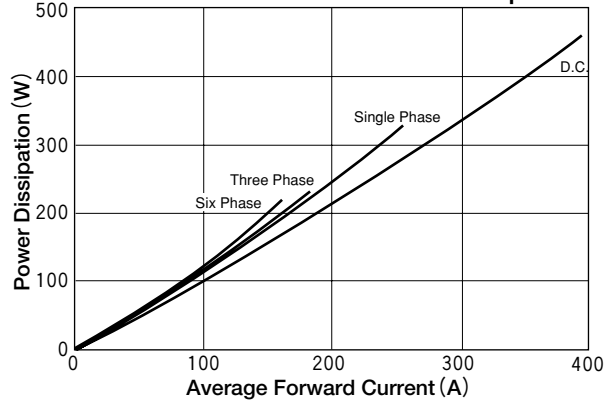

Average Forward Current vs. Allowable Case Temperature

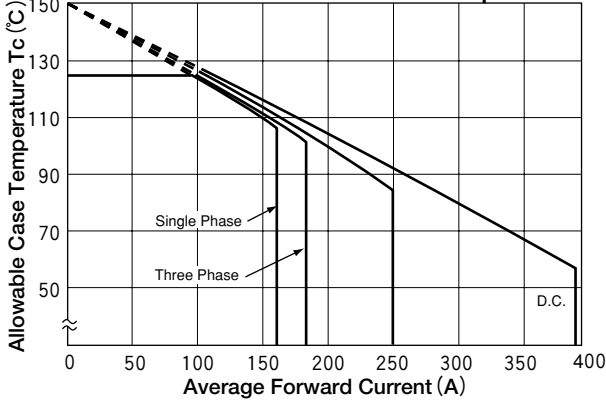

Cycle Surge Current Rating (Non-Repetitive)

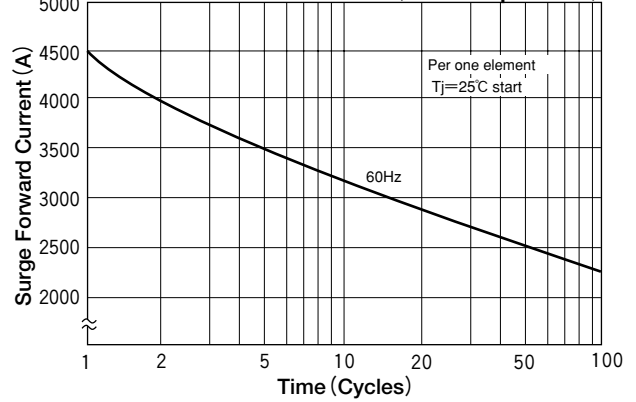

Transient Thermal Impedance

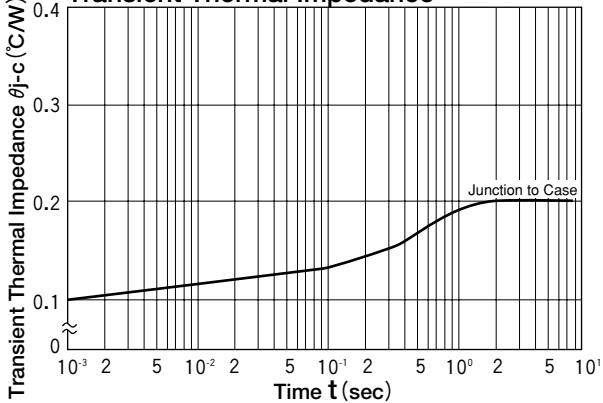

L Type

Maximum Forward Characteristics

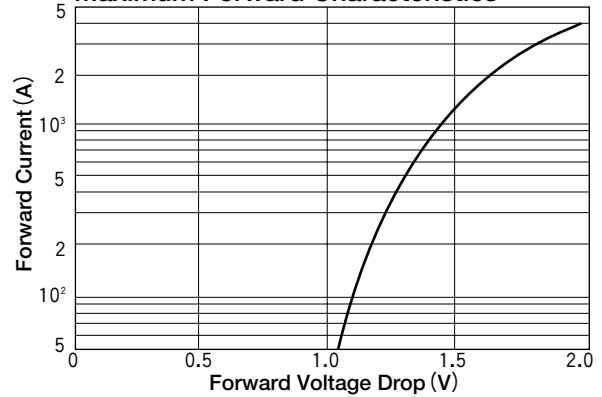

Average Forward Current vs. Power Dissipation

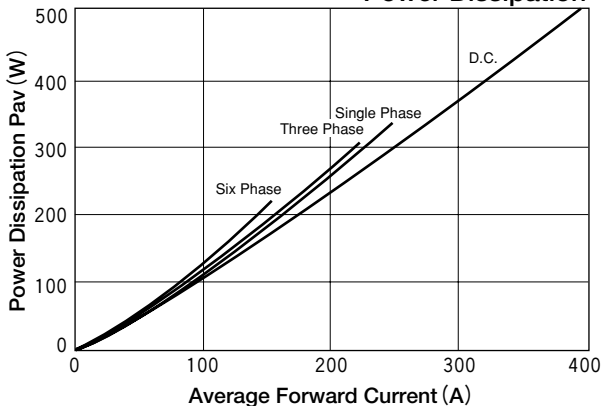

Average Forward Current vs. Allowable Case Temperature

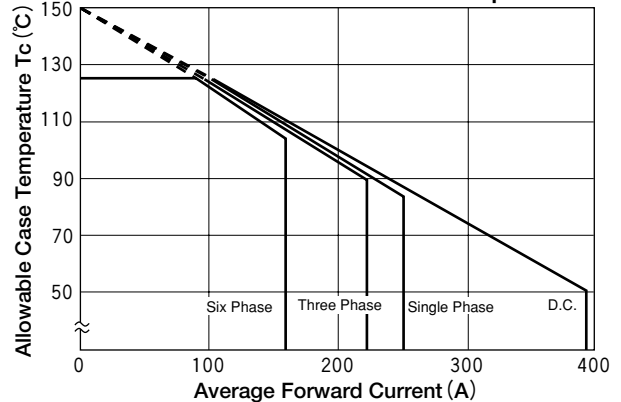

DIODE MODULE (F.R.D.)

FRS300BA50



UL;E76102 (M)

FRS300BA is a high speed (fast recovery) isolated diode module designed for high power switching application. FRS300BA is suitable for high frequency application requiring low loss and high speed control.

- High Speed $t_{rr} \leq 200\text{ns}$
- $I_{F(AV)}$ 300A
- Isolated Mounting base.
- High Surge Capability

(Applications)

- Inverter Welding Power Supply
- Power Supply for Telecommunication
- Various Switching Power Supply.

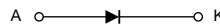
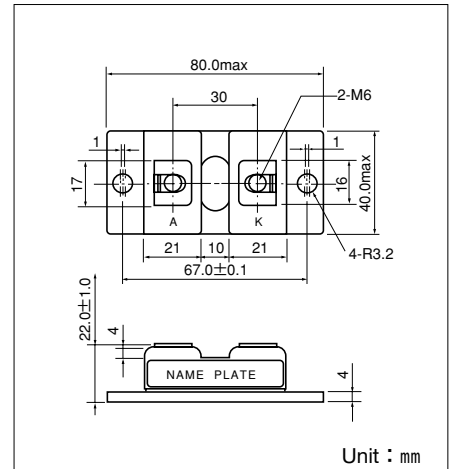

Unit : mm

Maximum Ratings

($T_j=25^\circ\text{C}$ unless otherwise specified)

Symbol	Item	Ratings	Unit
		FRS300BA50	
V_{RRM}	Repetitive Peak Reverse Voltage	500	V
$V_{R(DC)}$	D.C. Reverse Voltage	400	V

Symbol	Item	Conditions	Ratings	Unit	
$I_{F(AV)}$	Forward Current	D.C. $T_c : 85^\circ\text{C}$	300	A	
I_{FMS}	Surge Forward Current	$1/2$ cycle, 60Hz, peak value, non-repetitive	4000	A	
I^2t	I^2t	Value for one cycle of surge current	66600	A^2S	
T_j	Operating Junction Temperature		-40 to +150	$^\circ\text{C}$	
T_{stg}	Storage Temperature		-40 to +125	$^\circ\text{C}$	
V_{iso}	Isolation Breakdown Voltage (R.M.S.)	A.C. 1 minute	2500	V	
	Mounting Torque	Mounting (M6)	Recommended Value 2.5-3.9 (25-40)	4.7 (48)	N·m (kgf·cm)
		Terminal (M6)	Recommended Value 2.5-3.9 (25-40)	4.7 (48)	
	Mass	Typical Value	170	g	

Electrical Characteristics

Symbol	Item	Conditions	Ratings			Unit
			Min.	Typ.	Max.	
I_{RRM}	Repetitive Peak Reverse Current	$T_j=125^\circ\text{C}$, $V_{RRM}=500\text{V}$			300	mA
V_{FM}	Forward Voltage Drop	$T_j=25^\circ\text{C}$, $I_{FM}=300\text{A}$, Inst. measurement			1.3	V
t_{rr}	Reverse Recovery Time	$I_F=300\text{A}$, $-di/dt=300\text{A}/\mu\text{s}$			200	ns
$R_{th(j-c)}$	Thermal Impedance	Junction to case			0.165	$^\circ\text{C}/\text{W}$

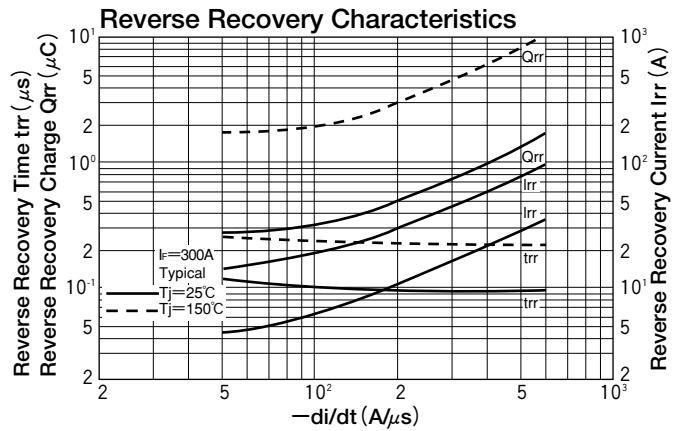
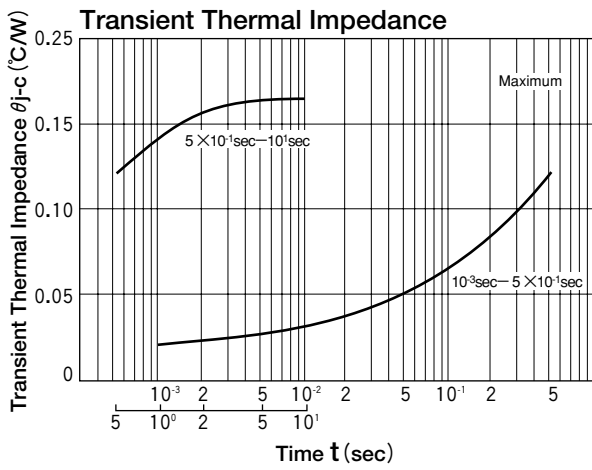
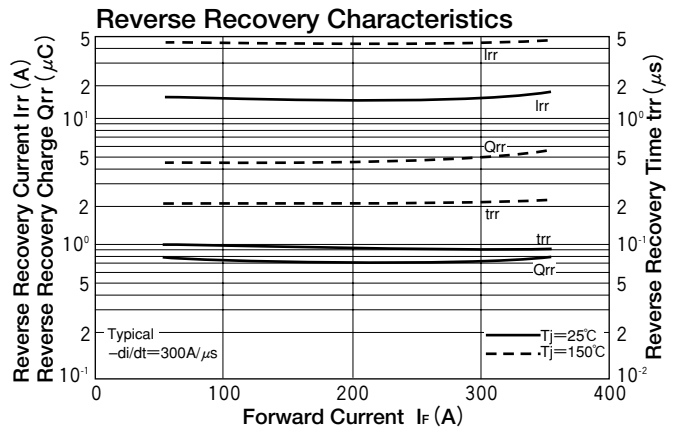
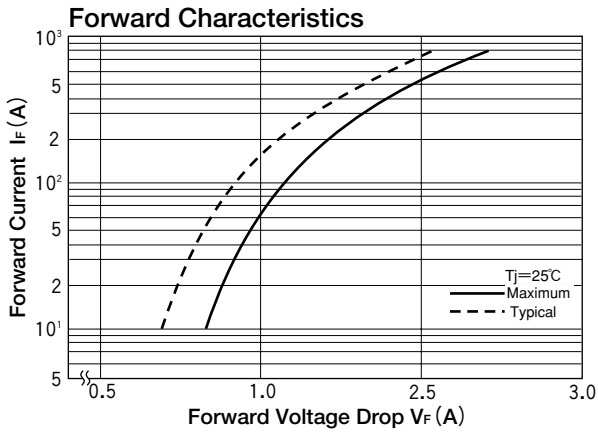

DIODE MODULE (F.R.D.)

FRS300CA50

TOP



UL;E76102 (M)

FRS300CA50 is a high speed (fast recovery) isolated diode module designed for high power switching application. FRS300CA50 is suitable for high frequency application requiring low loss and high speed control.

- High Speed $t_{rr} \leq 200\text{ns}$
- $I_F (AV)$ 300A
- Isolated Mounting base.
- High Surge Capability

(Applications)

- Inverter Welding Power Supply
- Power Supply for Telecommunication
- Various Switching Power Supply.

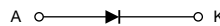
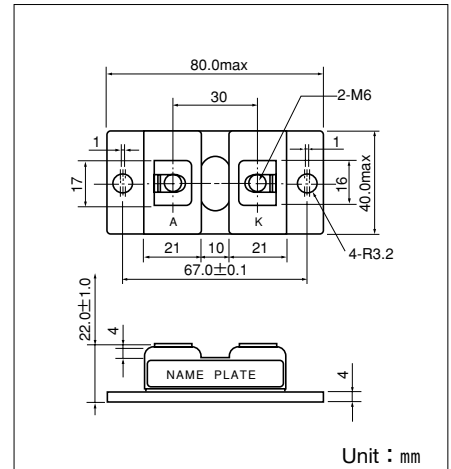

Unit : mm

Maximum Ratings

($T_j=25^\circ\text{C}$ unless otherwise specified)

Symbol	Item	Ratings	Unit
		FRS300CA50	
V_{RRM}	Repetitive Peak Reverse Voltage	500	V
$V_{R(DC)}$	D.C. Reverse Voltage	400	V

Symbol	Item	Conditions	Ratings	Unit	
$I_F (AV)$	Forward Current	D.C. $T_c : 116^\circ\text{C}$	300	A	
I_{FMS}	Surge Forward Current	$\frac{1}{2}$ cycle, 60Hz, peak value, non-repetitive	4000	A	
I^2t	I^2t	Value for one cycle of surge current	66600	A^2S	
T_j	Operating Junction Temperature		-40 to +150	$^\circ\text{C}$	
T_{stg}	Storage Temperature		-40 to +125	$^\circ\text{C}$	
V_{iso}	Isolation Breakdown Voltage (R.M.S.)	A.C. 1 minute	2500	V	
	Mounting Torque	Mounting (M6)	Recommended Value 2.5-3.9 (25-40)	4.7 (48)	N·m (kgf·cm)
		Terminal (M6)	Recommended Value 2.5-3.9 (25-40)	4.7 (48)	
	Mass	Typical Value	170	g	

Electrical Characteristics

Symbol	Item	Conditions	Ratings			Unit
			Min.	Typ.	Max.	
I_{RRM}	Repetitive Peak Reverse Current	$V_{RRM}=500\text{V}$, $T_j=125^\circ\text{C}$			300	mA
V_{FM}	Forward Voltage Drop	$I_F=300\text{A}$, Inst. measurement			1.3	V
t_{rr}	Reverse Recovery Time	$I_F=300\text{A}$, $-di/dt=300\text{A}/\mu\text{s}$			200	ns
$R_{th(j-c)}$	Thermal Impedance	Junction to case			0.085	$^\circ\text{C}/\text{W}$

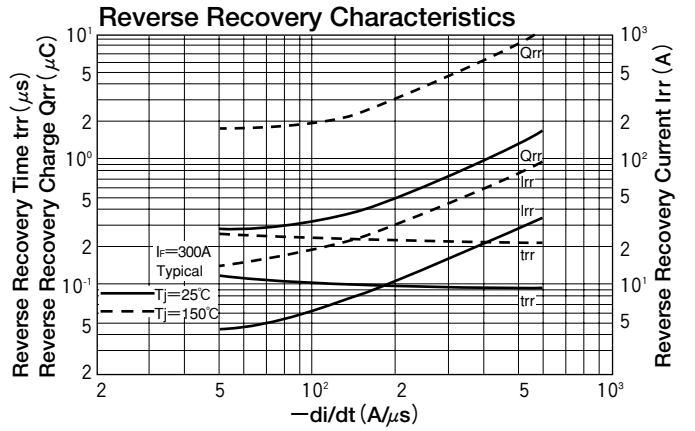
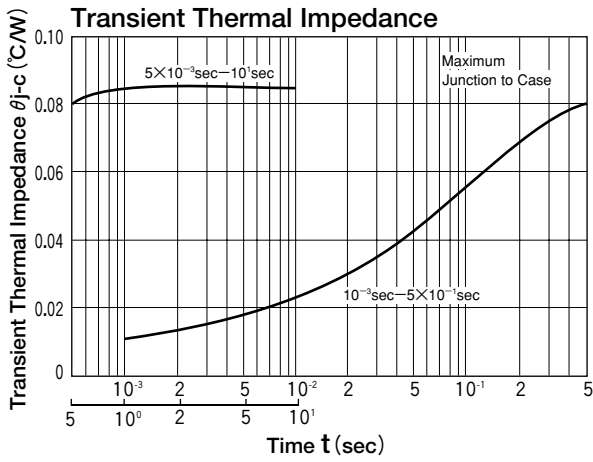
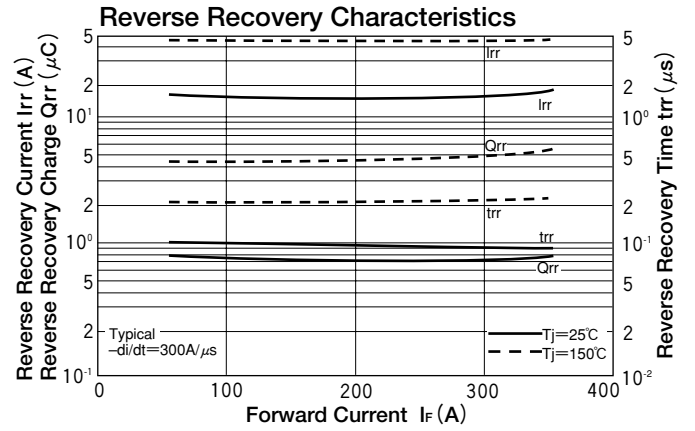
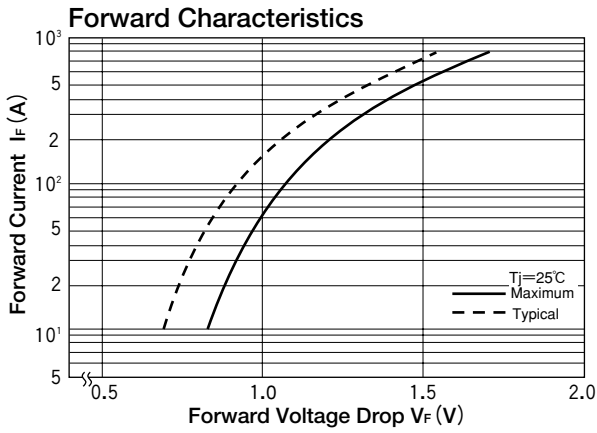

DIODE MODULE (F.R.D.)

FRS400BA50/60



UL;E76102 (M)

FRS400BA is a high speed (fast recovery) isolated diode module designed for high power switching application. FRS400BA is suitable for high frequency application requiring low loss and high speed control.

- High Speed $t_{rr} \leq 200\text{ns}$
- $I_{F(AV)}$ 400A
- Isolated Mounting base.
- High Surge Capability

(Applications)

Inverter Welding Power Supply
 Power Supply for Telecommunication
 Various Switching Power Supply.

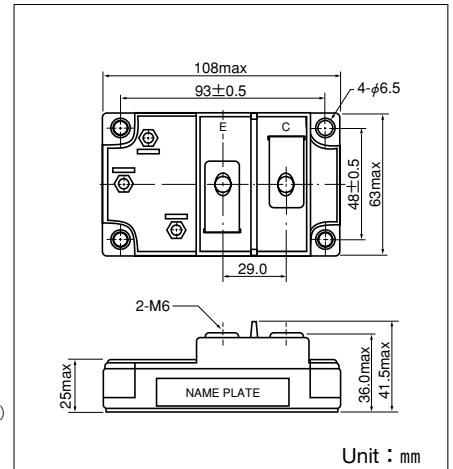
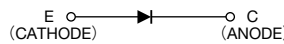

Unit : mm

Maximum Ratings

($T_j=25^\circ\text{C}$ unless otherwise specified)

Symbol	Item	Ratings		Unit
		FRS400BA50	FRS400BA60	
V_{RRM}	Repetitive Peak Reverse Voltage	500	600	V
$V_{R(DC)}$	D.C. Reverse Voltage	400	480	V

Symbol	Item	Conditions	Ratings	Unit	
$I_{F(AV)}$	Forward Current	D.C. $T_c : 94^\circ\text{C}$	400	A	
I_{FMS}	Surge Forward Current	$\frac{1}{2}$ cycle, 60Hz, peak value, non-repetitive	4000	A	
I^2t	I^2t	Value for one cycle of surge current	66640	A^2S	
T_j	Operating Junction Temperature		-40 to $+150$	$^\circ\text{C}$	
T_{stg}	Storage Temperature		-40 to $+125$	$^\circ\text{C}$	
V_{iso}	Isolation Breakdown Voltage (R.M.S.)	A.C. 1 minute	2500	V	
	Mounting Torque	Mounting (M6)	Recommended Value 2.5-3.9 (25-40)	4.7 (48)	N·m (kgf·cm)
		Terminal (M6)	Recommended Value 2.5-3.9 (25-40)	4.7 (48)	
	Mass	Typical Value	460	g	

Electrical Characteristics

Symbol	Item	Conditions	Ratings			Unit
			Min.	Typ.	Max.	
I_{RRM}	Repetitive Peak Reverse Current	$V_R=V_{RRM}, T_j=125^\circ\text{C}$			400	mA
V_{FM}	Forward Voltage Drop	$I_F=400\text{A}$, Inst. measurement		1.3	1.4	V
t_{rr}	Reverse Recovery Time	$I_F=400\text{A}, -di/dt=400\text{A}/\mu\text{s}$		130	200	ns
$R_{th(j-c)}$	Thermal Impedance	Junction to case			0.1	$^\circ\text{C}/\text{W}$



Forward Characteristics

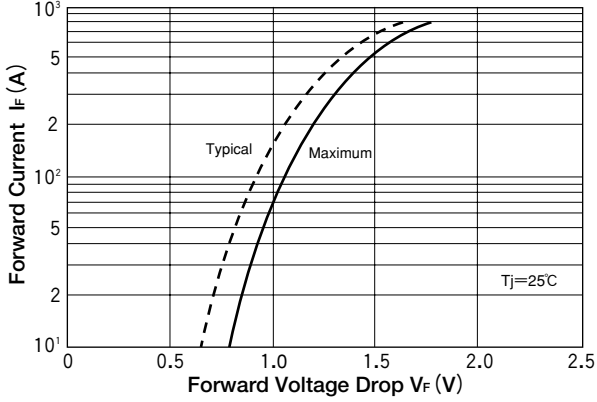

Reverse Recovery Characteristics

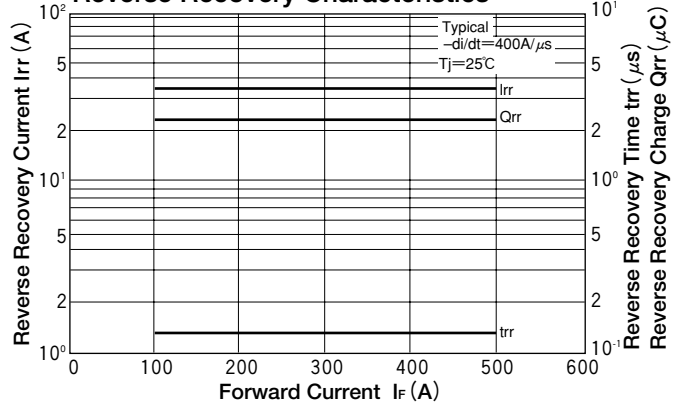

Transient Thermal Impedance

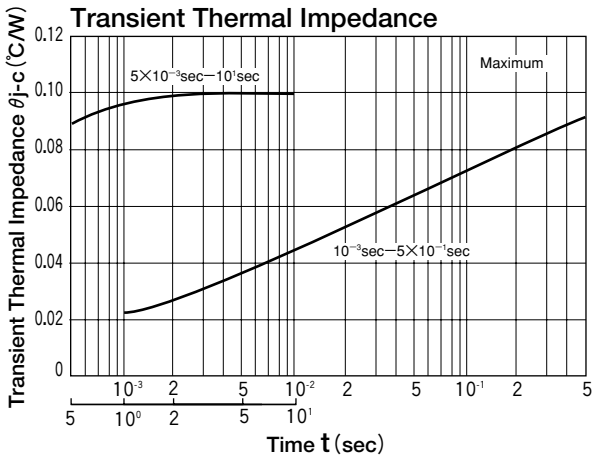

Reverse Recovery Characteristics

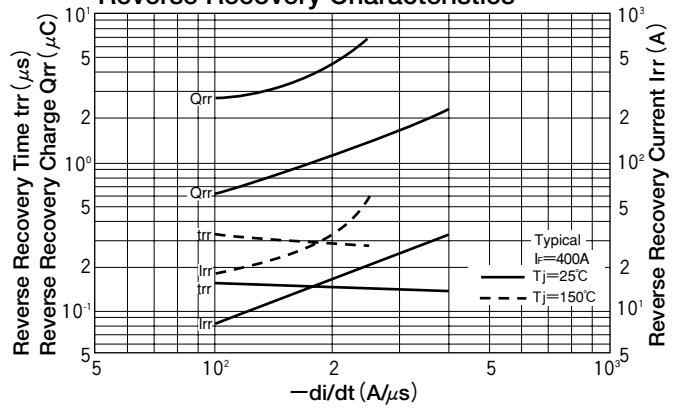

DIODE MODULE (F.R.D.)

FRS400CA120



UL;E76102 (M)

FRS400CA120 is a high speed (fast recovery) isolated diode module designed for high power switching application. FRS400CA120 is suitable for high frequency application requiring low loss and high speed control.

- High Speed $t_{rr} \leq 400\text{ns}$
- $I_F (AV)$ 400A
- Isolated Mounting base.
- High Surge Capability

(Applications)

Inverter Welding Power Supply
 Power Supply for Telecommunication
 Various Switching Power Supply.

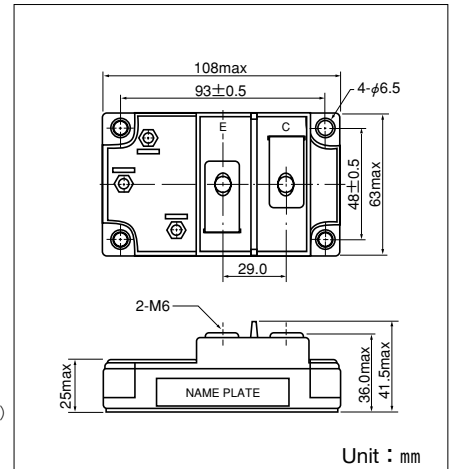
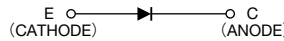

Maximum Ratings

($T_j=25^\circ\text{C}$ unless otherwise specified)

Symbol	Item	Ratings		Unit
		FRS400CA120		
V_{RRM}	Repetitive Peak Reverse Voltage	1200		V
$V_{R(DC)}$	D.C. Reverse Voltage	960		V

Symbol	Item	Conditions	Ratings	Unit	
$I_F (AV)$	Forward Current	D.C. $T_c : 78^\circ\text{C}$	400	A	
I_{FMS}	Surge Forward Current	$1/2$ cycle, 60Hz, peak value, non-repetitive	4000	A	
I^2t	I^2t	Value for one cycle of surge current	66640	A^2S	
T_j	Operating Junction Temperature		-40 to $+150$	$^\circ\text{C}$	
T_{stg}	Storage Temperature		-40 to $+125$	$^\circ\text{C}$	
V_{iso}	Isolation Breakdown Voltage (R.M.S.)	A.C. 1 minute	2500	V	
	Mounting Torque	Mounting(M6)	Recommended Value 2.5-3.9 (25-40)	4.7 (48)	N·m (kgf·cm)
		Terminal (M6)	Recommended Value 2.5-3.9 (25-40)	4.7 (48)	
	Mass	Typical Value	460	g	

Electrical Characteristics

Symbol	Item	Conditions	Ratings			Unit
			Min.	Typ.	Max.	
I_{RRM}	Repetitive Peak Reverse Current	$V_R=V_{RRM}, T_j=150^\circ\text{C}$			20	mA
V_{FM}	Forward Voltage Drop	$I_F=400\text{A}$, Inst. measurement			1.8	V
t_{rr}	Reverse Recovery Time	$I_F=400\text{A}, -di/dt=400\text{A}/\mu\text{s}$			400	ns
$R_{th(j-c)}$	Thermal Impedance	Junction to case			0.1	$^\circ\text{C}/\text{W}$



Forward Characteristics

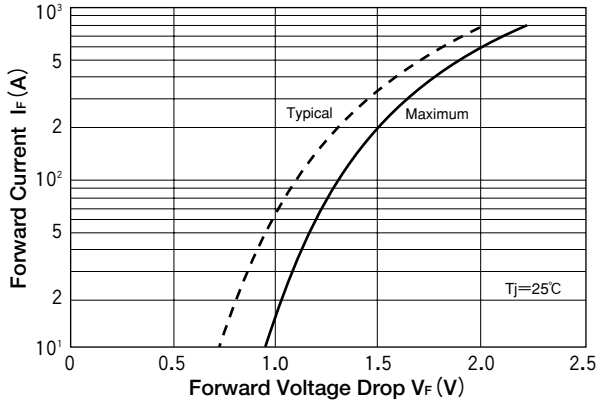

Reverse Recovery Characteristics

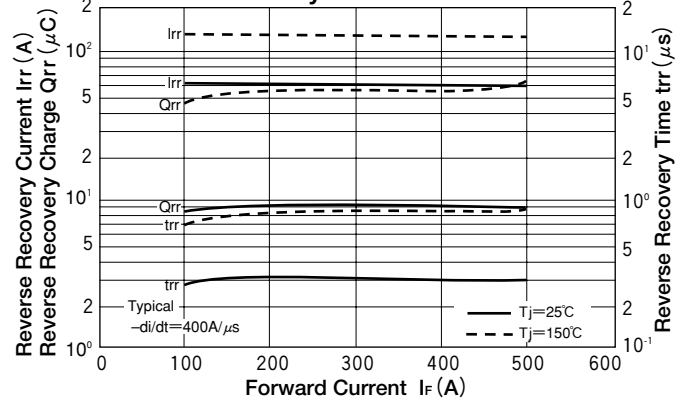

Transient Thermal Impedance

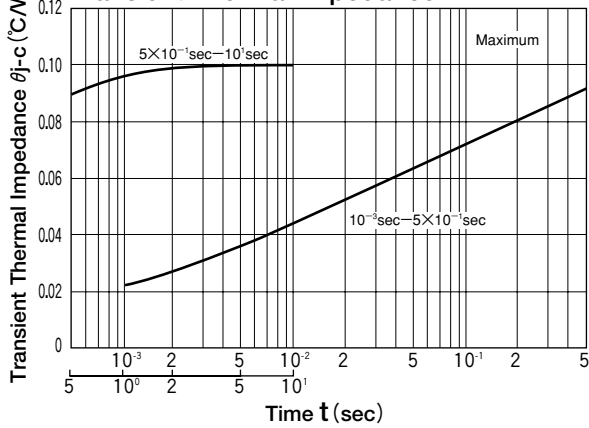

Reverse Recovery Characteristics

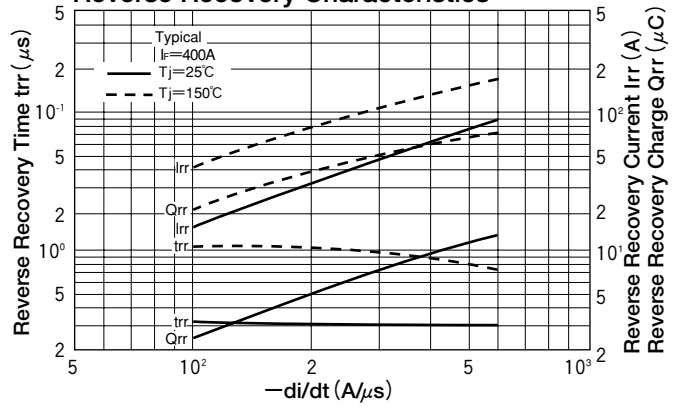

DIODE MODULE (F.R.D.)

FRS400DA100/120



UL;E76102 (M)

FRS400DA is a high speed (fast recovery) isolated diode module designed for high power switching application. FRS400DA is suitable for high frequency application requiring low loss and high speed control.

- High Speed $t_{rr} \leq 200\text{ns}$
- $I_F (AV)$ 400A
- Isolated Mounting base.
- High Surge Capability

(Applications)

Inverter Welding Power Supply
 Power Supply for Telecommunication
 Various Switching Power Supply.

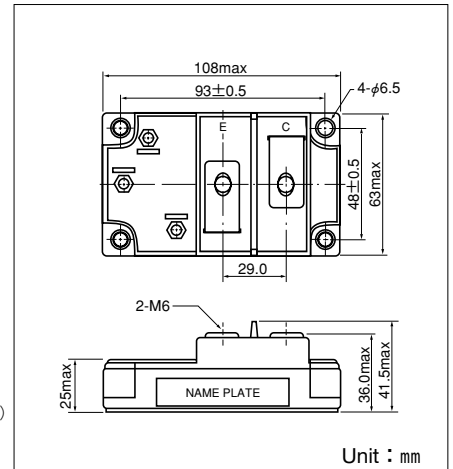
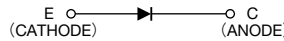

Unit : mm

Maximum Ratings

($T_j = 25^\circ\text{C}$ unless otherwise specified)

Symbol	Item	Ratings		Unit
		FRS400DA100	FRS400DA120	
V_{RRM}	Repetitive Peak Reverse Voltage	1000	1200	V
$V_{R(DC)}$	D.C. Reverse Voltage	800	960	V

Symbol	Item	Conditions	Ratings	Unit	
$I_F (AV)$	Forward Current	D.C.	400	A	
I_{FMS}	Surge Forward Current	$1/2$ cycle, 60Hz, peak value, non-repetitive	4000	A	
I^2t	I^2t	Value for one cycle of surge current	66640	A^2S	
T_j	Operating Junction Temperature		-40 to +150	$^\circ\text{C}$	
T_{stg}	Storage Temperature		-40 to +125	$^\circ\text{C}$	
V_{iso}	Isolation Breakdown Voltage (R.M.S.)	A.C. 1 minute	2500	V	
	Mounting Torque	Mounting(M6)	Recommended Value 2.5-3.9 (25-40)	4.7 (48)	N·m (kgf·cm)
		Terminal (M6)	Recommended Value 2.5-3.9 (25-40)	4.7 (48)	
	Mass	Typical Value	460	g	

Electrical Characteristics

Symbol	Item	Conditions	Ratings			Unit
			Min.	Typ.	Max.	
I_{RRM}	Repetitive Peak Reverse Current	$V_R = V_{RRM}$, $T_j = 150^\circ\text{C}$			20	mA
V_{FM}	Forward Voltage Drop	$I_F = 400\text{A}$, Inst. measurement		2.4	2.8	V
t_{rr}	Reverse Recovery Time	$I_F = 400\text{A}$, $-di/dt = 400\text{A}/\mu\text{s}$		180	200	ns
$R_{th(j-c)}$	Thermal Impedance	Junction to case			0.1	$^\circ\text{C}/\text{W}$

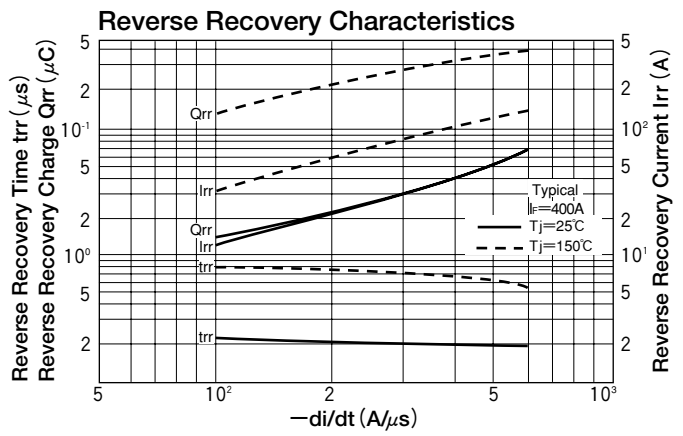
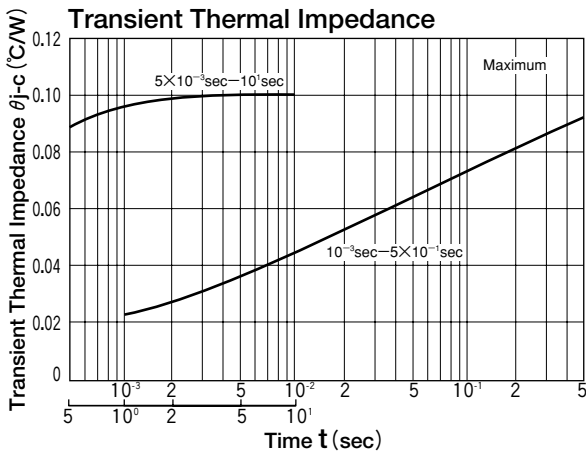
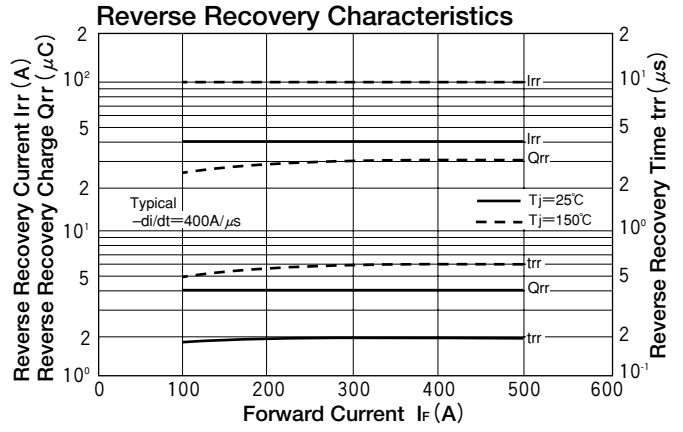
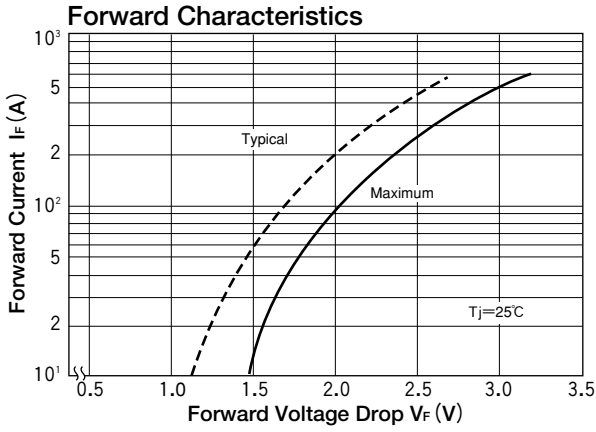

DIODE MODULE (F.R.D.)

FRS400EA180/200



UL;E76102 (M)

FRS400EA is a high speed isolated diode module designed for high power switching application. FRS400EA is suitable for high frequency application requiring low loss and high speed control.

- High Speed $t_{rr} \leq 700\text{ns}$
- $I_F (AV)$ 400A
- Isolated Mounting base.
- High Surge Capability

(Applications)

Inverter Welding Power Supply
 Power Supply for Telecommunication
 Various Switching Power Supply.

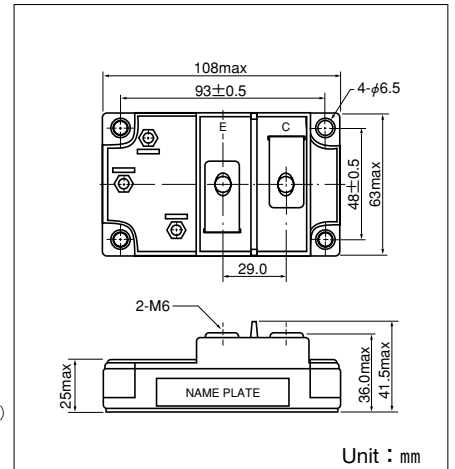
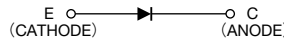

Maximum Ratings

(T_j=25°C unless otherwise specified)

Symbol	Item	Ratings		Unit
		FRS400EA180	FRS400EA200	
V _{RRM}	Repetitive Peak Reverse Voltage	1800	2000	V
V _{R(DC)}	D.C. Reverse Voltage	1440	1600	V

Symbol	Item	Conditions	Ratings	Unit	
I _{F(AV)}	Forward Current	D.C. T _c : 79°C	400	A	
I _{FMS}	Surge Forward Current	1/2 cycle, 60Hz, peak value, non-repetitive	5000	A	
I ² t	I ² t	Value for one cycle of surge current	104000	A ² S	
T _j	Operating Junction Temperature		-40 to +150	°C	
T _{stg}	Storage Temperature		-40 to +125	°C	
V _{iso}	Isolation Breakdown Voltage (R.M.S.)	A.C. 1 minute	2500	V	
	Mounting Torque	Mounting(M6)	Recommended Value 2.5-3.9 (25-40)	4.7 (48)	N·m (kgf·cm)
		Terminal (M6)	Recommended Value 2.5-3.9 (25-40)	4.7 (48)	
	Mass	Typical Value	460	g	

Electrical Characteristics

Symbol	Item	Conditions	Ratings			Unit
			Min.	Typ.	Max.	
I _{RRM}	Repetitive Peak Reverse Current	V _R =V _{RRM} , T _j =150°C			100	mA
V _{FM}	Forward Voltage Drop	T _j =125°C, I _F =400A, Inst. measurement			2.20	V
t _{rr}	Reverse Recovery Time	I _F =400A, -di/dt=400A/μs			700	ns
R _{th(j-c)}	Thermal Impedance	Junction to case			0.08	°C/W

